



# HANSA-TMP

MANUFACTURING YOUR SUCCESS

HT 16 / M / 174 / 1121 / E

THE PRODUCTION LINE OF HANSA-TMP

## Variable Displacement Closed Loop System Axial Piston Compact Tandem Pump

### TPV 1300 BTB

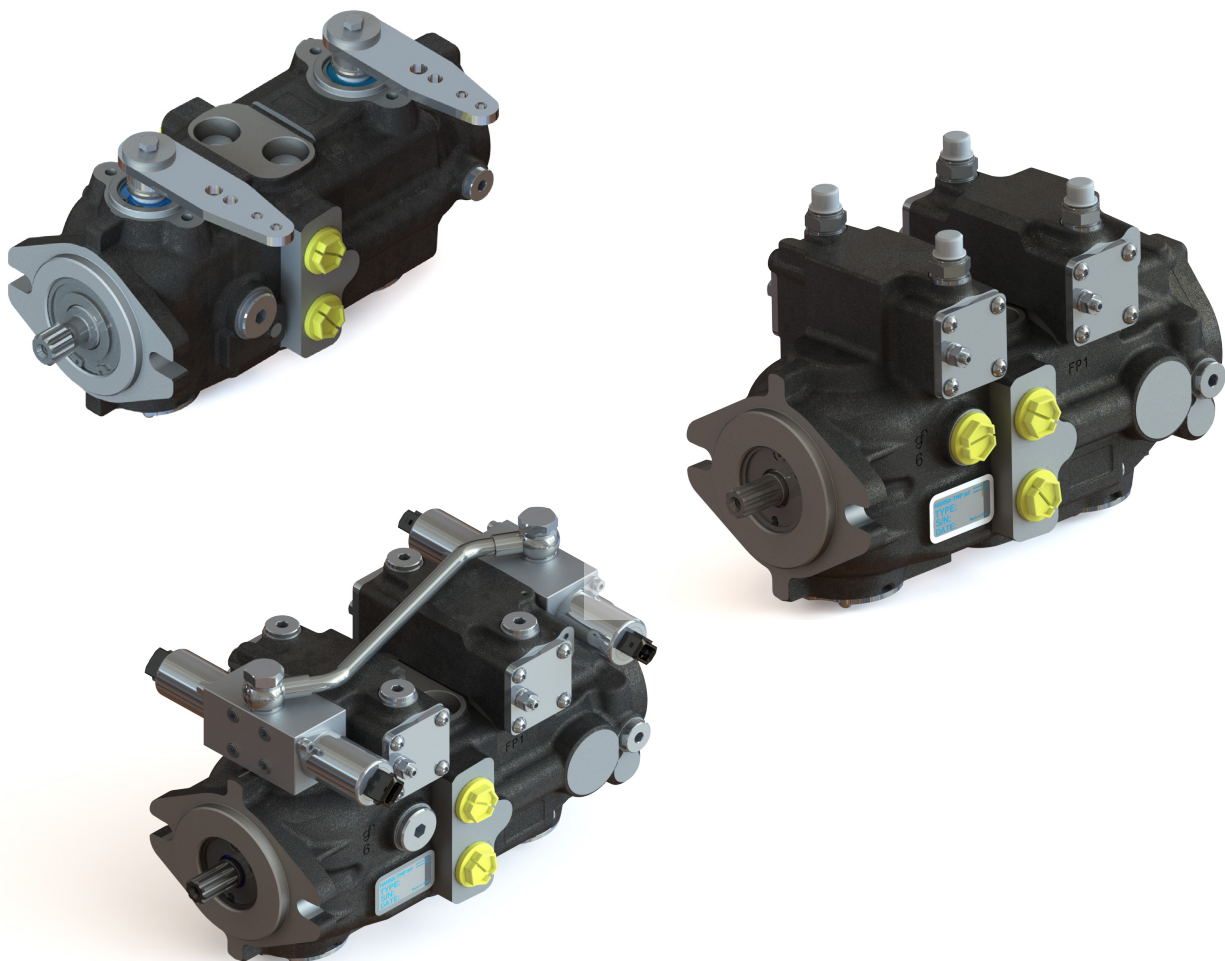



**INDEX**

General information.....4  
Technical specifications.....5  
System design parameters.....6  
Performance diagram.....7  
Torque Calculation.....8  
Installation instructions.....9 - 10  
Hydraulic fluid.....11  
Hydraulic fluid filtration.....12

**TPV 1300 BTB**

Order code..... 13 - 15  
Tandem Pump - Direct Mechanical Control (overall dimensions).....16  
Tandem Pump - Hydraulic Servo Control (overall dimensions).....17  
Tandem Pump - Electro Proportional Servo Control (overall dimensions)..... 18  
Mounting flanges and shaft..... 19 - 21  
DM Direct mechanical control..... 22 - 23  
BC Tapered bush..... 24  
LC Direct mechanical control with lever..... 25  
DMS Control lever with return to zero position (torsion spring).....26 - 27  
DMZ Control lever with return to zero position (compression spring)..... 28 - 29  
SHI Integrated hydraulic servo control.....30 - 31  
SHIC Compact hydraulic control.....32 - 33  
SEI 1 - 2 Electro-proportional servo control (AMP Junior).....34 - 36  
SEI 1 - 2 D Electro servo control (DEUTSCH).....37 - 38  
Control devices positions.....39 - 40  
Rear flange for auxiliary pump.....41  
Rear pump mounting flanges.....42  
OPTIONAL FB Adaptor flange SAE A - SAE B..... 43  
OPTIONAL ST.....43  
OPTIONAL VS-SB Flushing valve with screw by-pass.....44  
OPTIONAL VS-SB1 Flushing valve with screw by-pass (180° rotated position).....45  
OPTIONAL SB Screw by-pass .....46  
OPTIONAL SB1 Screw by-pass (180° rotated position)..... 47  
OPTIONAL FBST SAE-A / SAE-B flange.....48  
OPTIONAL MOB Man on board.....49 - 50  
Troubleshooting..... 51  
Accessories.....52  
Triple pump..... 53

## GENERAL INFORMATION

---

- TPV 1300 BTB is a variable displacement, compact tandem axial piston pump, with swashplate system, for closed loop hydrostatic transmissions.
- Flow rate is proportional to the rotation speed and displacement, and is continuously variable.  
It increases as the swashplate angle moves from "0" to maximum position.  
If the swashplate is positioned beyond the neutral point, the flow rate respectively follows one of the two directions.
- The TPV 1300 BTB is equipped with a boost pump, "gerotor" type of new design and high efficiency to keep the circuit pressurised, to compensate the oil leakages of the hydrostatic transmission, to avoid cavitation of the piston pump and to supply low pressure oil flow to the remote controls of the pumps and of the hydraulic transmission (max 3 MPa).
- The standard version is of mechanical type on which, by means of a lever, the change of flow in the two directions is obtained.
- This series of pumps can be with a hydraulic servo control or electro-proportional control which allows the control of the pump by means of hydraulic or electric joysticks.
- Moreover the pump is fitted with relief valves and it is adapted for assembly of auxiliary gear pumps.
- The compact tandem TPV 1300 BTB, are available with splined or parallel shaft and can be supplied with options such as purge valve, screw by-pass valve and, for security, "man on board" valve.
- The piston pumps are to be considered as individual components for the purposes of Directive 98/37/EC, therefore have been built to be integrated into a circuit or to be assembled with other components to form a machine or system. They can be operated only after they have been installed in the machine/system which they are intended for.
- The TPV 1300 BTB pumps must be used to create, manage and regulate oil flow in a closed loop system. Any other use should be considered improper.
- The pumps are built according to the technology normally used for this type of product. There is the risk of injury or damage to personnel during their installation and use if you do not respect the normal safety instructions or if used by untrained personnel.



## TECHNICAL SPECIFICATIONS

The housing and the distributor cover of the pumps TPV 1300 are made in cast iron. The flow rate is proportional to the rotation speed and the displacement is continuously variable. It increases as the swash-plate angle moves from "0" to maximum position. If the swash-plate is positioned out of the neutral position, the flow respectively follows one of the two directions.

- forest vehicles
- logistic machines

### Typical applications

- construction equipment
- green mowers
- zero turn machines
- agricultural machines
- utility vehicles

PUMP MODEL		TPV 6-7	TPV 8-7	TPV 9-7	TPV 11-7	TPV 12-7	TPV 13-7	TPV 15-9	TPV 17-9	TPV 18-9	TPV 19-9	TPV 21-9
Max. Displacement	cm <sup>3</sup>	7,4	8,9	9,6	11,2	12,8	13,6	15,00	17,1	18,2	19,4	21,15
Flow rating <sup>(1)</sup>	l/min	25,01	31,96	34,74	40,32	46,08	48,88	54,00	61,77	66,37	69,84	76,4
Power rating <sup>(1)</sup>	kW	8,75	11,18	12,15	14,11	16,12	17,11	18,9	21,61	23,23	24,44	31,73
Boost pump displacement	cm <sup>3</sup> /n	5,4										
Rated pressure	MPa	30						25			22	
Max. pressure	MPa	35	35	35	35	35	35	30	30	30	28	
Max. relief valve setting	MPa	38										
Standard boost pressure <sup>(2)</sup>	MPa	0,6 (Mechanical Control) 2 (Hydraulic / Electric Servo Control)										
Suction pressure	MPa (assoluta)	> = 0,08										
Max. case pressure	MPa	0,15										
Min. shaft speed	n/min	500										
Rated speed	n/min	3.600									2900	
Max. speed	n/min	3.900									3200	
Max. oil temperature	°C	80										
Oil viscosity	cSt	15-35										
Fluid contamination		18/15/12 ISO 4406 (NAS 7)										
Dry weight (single pump) <sup>(3)</sup>	kg	11										
Dry weight (tandem pump) <sup>(3)</sup>	kg	23										

(1) 3.600 n/min 21 MPa

(2) 1.000 n/min

(3) Nominal data, weight varies depending on configuration and optional

SYSTEM DESIGN PARAMETERS

HYDRAULIC MEASURE	USEFUL FORMULAS	CONVERSION FACTORS
Flow rate: Q = (l/min)	$Q = V [\text{cm}^3/\text{n}] \times \eta_v \times n \times 10^{-3}$	1 l/min = 0,2641 US Gal/min
Pressure: P = (MPa)		1 MPa = 145 PSI
Displacement: V = (cm <sup>3</sup> /n)		
Torque: M = (Nm)	$M = \frac{\Delta p [\text{MPa}] \times V [\text{cm}^3/\text{n}]}{6.283 \times \eta_m}$	1 Nm = 8,851 in lbs
Power: P = (kW)	$P = \frac{\Delta p [\text{MPa}] \times V [\text{cm}^3/\text{n}] \times n}{60 \times 1000 \times \eta_t}$	1 KW = 1,36 HP
Shaft speed: n = n/min		
Hydraulic efficiency: = $\eta_v$		
Mechanical efficiency: = $\eta_m$		
Overall efficiency: = $\eta_t$		
		1 mm = 0,0394 in
		1 kg = 2,205 lbs
		1 N = 0,2248 lbs

**PERFORMANCE DIAGRAM**

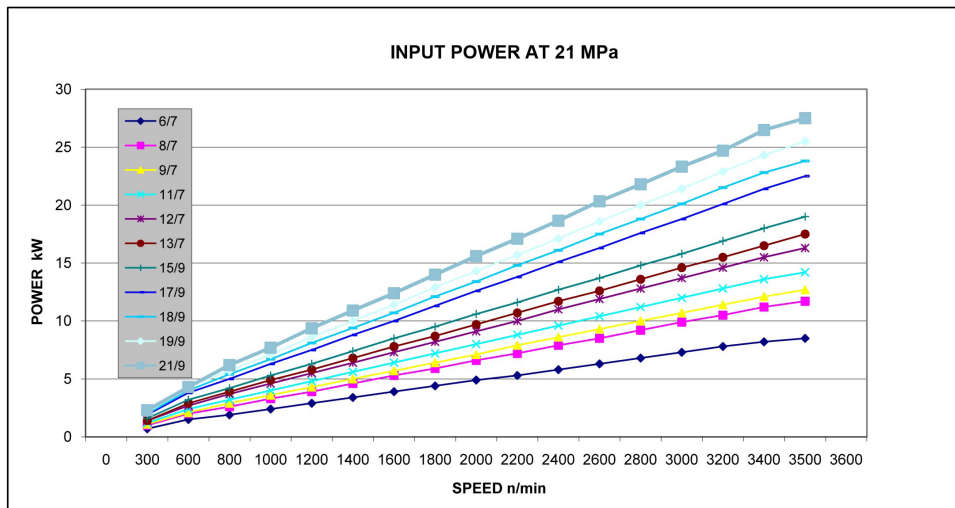
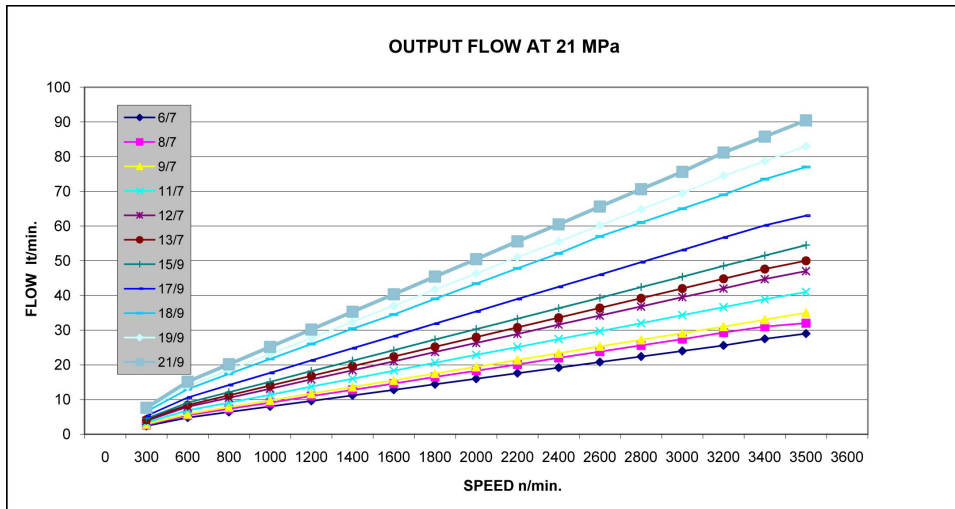

**Performance diagrams**

- The diagrams show the data of maximum speed and maximum continuous pressure.
- Data may vary depending on pump displacement.

**Pressure**

- Continuous pressure: is the average pressure for continuous work, which must not be exceeded, to ensure a correct and long lasting service of the pump.
- Maximum pressure: is the maximum allowable pressure for short periods and must never be exceeded.

**Speed**

- Continuous work speed: is the maximum recommended speed for continuous operation of the pump under full load.

- Maximum speed: is the maximum permissible speed for the pump for short periods and not fully loaded. The use of the pump with this speed can reduce the life cause a loss of power or hydrostatic braking capacity.

**Caution**

Any damage caused to the pump can reduce or eliminate the hydrostatic braking capacity. It is therefore necessary to provide an auxiliary braking system capable of stopping and supporting the weight of the complete machine, in the event of loss of hydrostatic power.

**TORQUE CALCULATION**

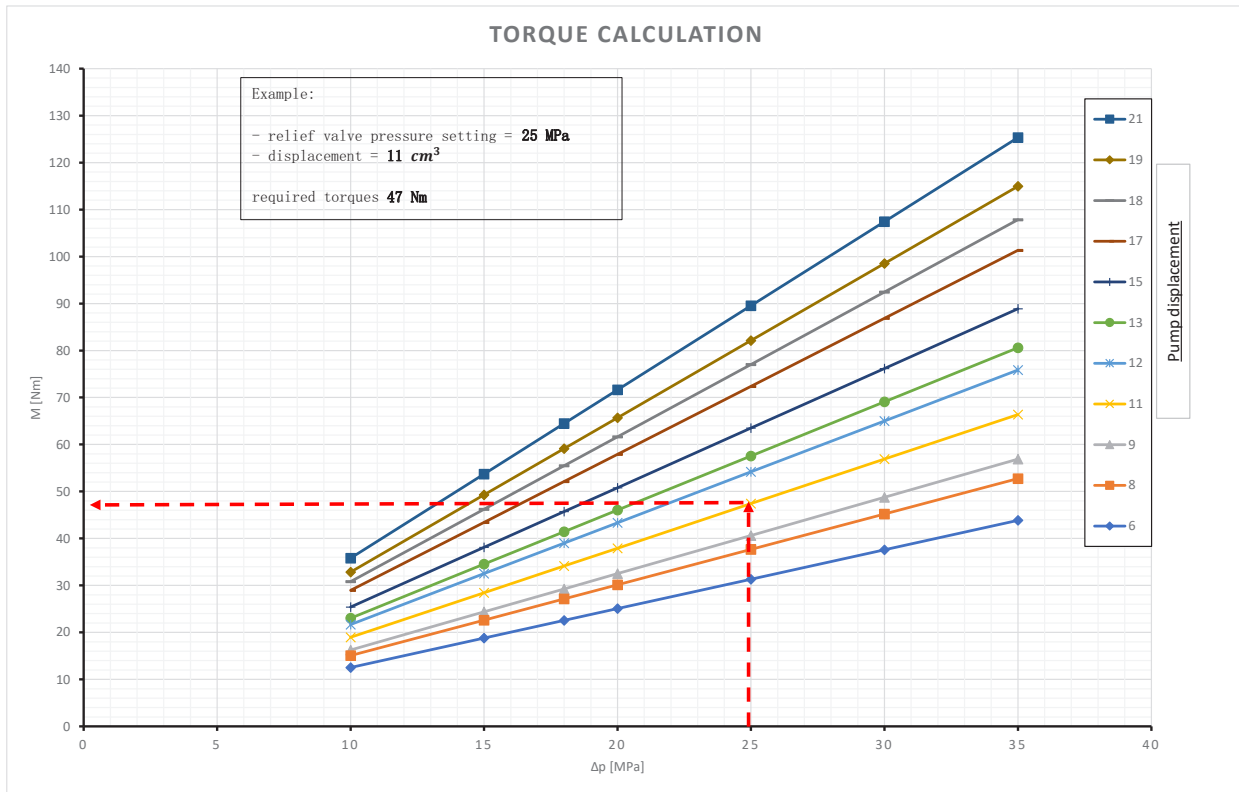

For a correct selection of the product, it is necessary to verify that the selected shaft is able to guarantee the mechanical resistance to the specific operating conditions.

The check involves comparing the torque value reached in the heaviest working condition with the one allowed by the pump shaft.

For multiple pump, is necessary to consider the sum of the torques required for each pump units.

The displacements and the working pressures for each unit are required for the verification. With these data is possible to calculate analytically or through the use of graph, the total torque required to the shaft.

The following equation shows the torque value:

$$M [Nm] = \sum_{i=1}^k \frac{V_i \left[ \frac{cm^3}{n} \right] \cdot \Delta p_i [MPa]}{2 \cdot \pi \cdot \eta_m}$$

V<sub>i</sub> = i pump displacement i, expressed in cm<sup>3</sup>;

Δp<sub>i</sub> = i pressure difference between pump inlet and outlet, expressed in bar;

η<sub>m</sub> = mechanical efficiency that we can assume equal to 0,94;

k = number of pumps.

## INSTALLATION INSTRUCTIONS

### Standards for the installation, start up and maintenance

- When mounting the pump above the minimum level of the tank, distance of the highest point of the pump over the oil level **MUST NOT** exceed 250 mm.
- To reduce the noise level typical of all piston pumps we recommend:
  - use hoses instead of pipes
  - limit to a minimum the length of eventual pipes
  - fix rigid pipe sections with special supports equipped with rubber vibration dampening devices
  - use pipes and hoses with a diameter according to the speed values below:

Suction line =  $0,6 \div 1,2 \text{ m / s}$

Drain =  $1,5 \div 3,6 \text{ m / s}$

Pressurized lines = max  $6 \text{ m / s}$

- To calculate the speed of the oil in the lines refer to the formula below:

$$V = (Q * 21,22) / D$$

V = speed (m/s)

Q = flow rate (l/min)

D = internal pipe/hose diameter (mm)

- In any case **NEVER** use pipes/hoses or fittings with diameter smaller than that of the corresponding ports on the pump. This indication is **ABSOLUTELY OBLIGATORY** for the drain line to avoid to pressurize the pump housing and extrude the lip seal of the pump shaft.
- During mounting cure the alignment of the pump, concentric with the drive shaft sleeve to prevent overloading of the bearing.
- For the hydraulic system, we recommend using pipes/hoses washed internally with hydraulic oil or, even better, with solvent.
- Special care must be taken when cleaning the inside of the tank (painting is recommended after sand blasting).
- To improve the functionality of the boost pump, it is recommended to place it below minimum tank level.
- The pumps can be installed in any direction and position.  
For further information contact our Technical Department.

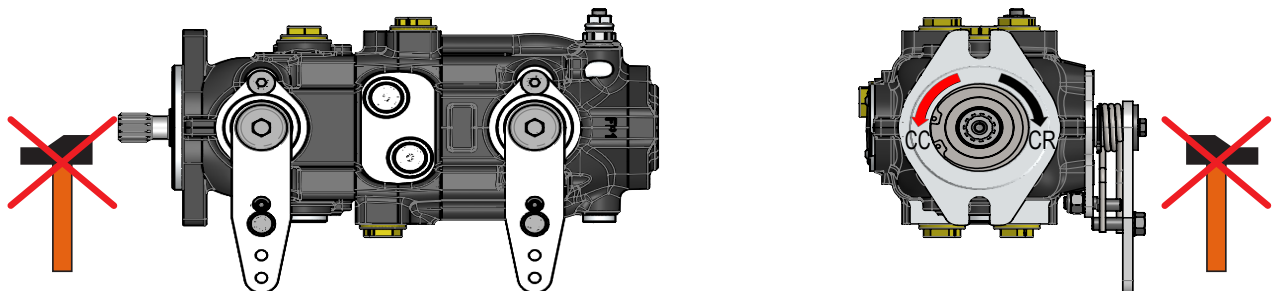

(continued)

## INSTALLATION INSTRUCTIONS

### Shaft Coupling

To connect the pump shaft to the engine flywheel or prime motor shaft use a flexible

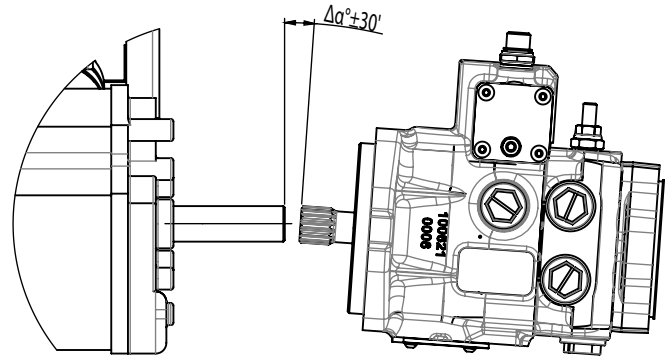
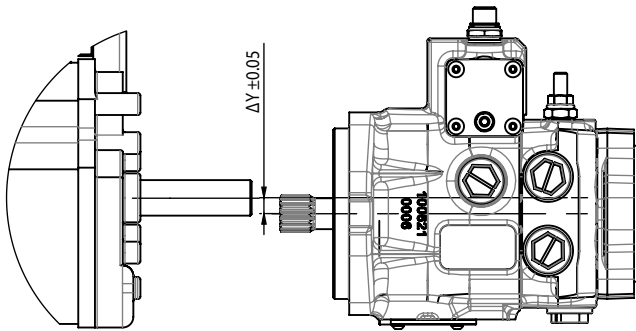

coupling. The alignment must be within the tolerances indicated in the figures below. For an optimal function of the pump the shaft should not be subjected to radial or axial loads. In the presence of radial and axial loads the maximum allowable values are shown below.

During the installation or removal, do not force the coupling of the pump shaft, but always use the threaded hole on the shaft.

### Start up

- Before starting fill the tank and the other components with new filtered oil. You should run a flushing of the complete hydraulic system (see Use and Maintenance Manual). Check that the low pressure value is correct (refer to the Use and Maintenance Manual).
- Restore the oil level in the tank.

### Maintenance

- The first oil change should be made after 500 hours of operation. Later change the oil every 2000 hours.
- The first replacement of the filter cartridge has to be made after 50 hours for a preliminary circuit cleaning. Then after further 500 hours.

- These frequencies have to be reduced in the case where the indicator shows the clogging of the filter cartridge and in case of operation in environments with a high level of contamination.

### CAUTION

- Always work with the utmost attention to the moving parts; do not use loose or fluttering clothing.
- Do not approach rotating wheels, tracks, chains or shafts if not properly protected, or when they may start moving without notice.
- Do not loosen or disconnect fittings and pipes/hoses while the engine is running.
- Avoid oil leaks in order to prevent environmental pollution.

### Load capacity of rear shaft (through drive shaft)

- The rear shaft is not able to carry radial loads.

**HYDRAULIC FLUID**

**Viscosity**

The maximum duration and the maximum efficiency are related to the optimum range of viscosity.

Viscosity = optimal operating viscosity 15 ÷ 40 cSt referred to the temperature of the closed circuit.

Minimum viscosity = 10 cSt for short moments and with the maximum temperature of the drain oil at 90 °C.

Max. viscosity = 1000 cSt for a few seconds, only during cold starting.

**Working conditions**

For working conditions apply the following limits:

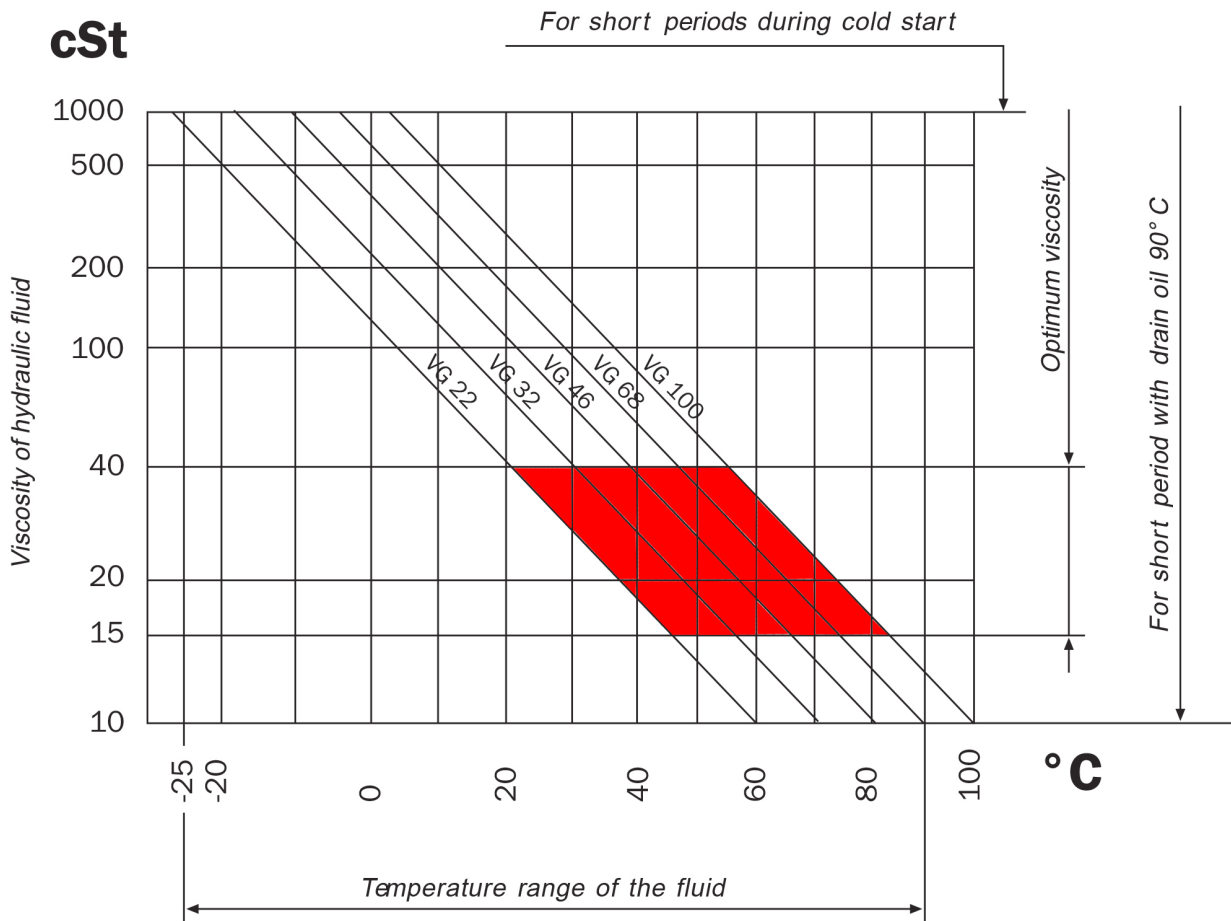

HANSA - TMP cannot be held responsible concerning non compliance of these instructions and observance of safety regulations, although not covered by this document.

## HYDRAULIC FLUID FILTRATION

---

The contaminating particles suspended in the hydraulic fluid cause the wear of the hydraulic mechanisms moving parts.

On hydraulic pumps these parts operate with very small dimensional tolerances.

In order to prolong the parts life, it is recommended to use a filter that maintains the hydraulic fluid contamination class at max.

8 according to NAS 1638  
5 according to SAE, ASTM, AIA  
19/17/14 according to ISO 4406

According to the type of application decided for the pump, it is necessary to use filtration elements with a filtration ratio of:

$$\beta_{(x)} 20 \div 30 \geq 75$$

making sure that this ratio does not worsen together with the increasing of the filter cartridge differential pressure. While the pump is working, its temperature increases (over 80° to 110°C) with negative effects on pump performances; as a consequence, it is important to observe a max. contamination level of:

7 according to NAS 1638  
4 according to SAE, ASTM, AIA  
18/16/13 according to ISO 4406

If these values cannot be secured, the component life will consequently be reduced and it is recommended to contact our Tech. Dept.

### Suction filters

The suction filters will have a clogging indicator and bypass. The max. pressure drop of the filtration element must not exceed 0,04 absolute MPa (0,08 absolute MPa with cold start).

### Filter assembling

The suction filter is mounted in the suction line. Check that the pressure before the boost pump is 0,8 absolute bar, measured on the pump suction port (0,05 MPa for cold starting).



**ORDER CODE**

0	1	2	3	4	5	6	7	8	9	10	11	12	13	14	15	16	17	18
TPV / TPVS	1300	06   06	CR	SS2	B	F1	SHI   SHI	OAL   OAL	20   20	06	20	000	B2	000	0	00	G	00
TPVT3		06   06   06					SHI   SHI   SHI	OAL   OAL   OAL	20   20   20									

Pag.

<b>TPV</b>	<b>0 - Pump model</b>	
<b>TPVS</b>	= Closed loop circuit tandem pump	
<b>TPV-T3</b>	= Closed loop circuit special tandem pump	
	= Closed loop circuit triple pump	
<b>1300</b>	<b>1 - Pump series</b>	
	= TPV Pump 1300	
	<b>2 - Pump displacement</b>	
	<b>6</b> = 7,4 cm <sup>3</sup> /n	<b>8</b> = 8,9 cm <sup>3</sup> /n
	<b>12</b> = 12,8 cm <sup>3</sup> /n	<b>13</b> = 13,6 cm <sup>3</sup> /n
	<b>18</b> = 18,2 cm <sup>3</sup> /n	<b>19</b> = 19,4 cm <sup>3</sup> /n
	<b>9</b> = 9,6 cm <sup>3</sup> /n	<b>11</b> = 11,2 cm <sup>3</sup> /n
	<b>15</b> = 15 cm <sup>3</sup> /n	<b>17</b> = 17,1 cm <sup>3</sup> /n
	<b>21</b> = 21,15 cm <sup>3</sup> /n	
<b>CR</b>	<b>3 - Rotation</b>	
<b>CC</b>	= Clockwise rotation (right)	
	= Counter-clockwise rotation (left)	
<b>PS3</b>	<b>4 - Shaft</b>	<b>19</b>
<b>SS2</b>	= Parallel keyed shaft 18 mm. diam. with increased bearing for external radial load	<b>19</b>
<b>SS3</b>	= Splined shaft Z9 - 16/32" D.P.	<b>19</b>
<b>SS4</b>	= Splined shaft Z13 - 16/32 D.P.	<b>20</b>
	= Splined shaft Z11 - 16/32 D.P.	<b>20</b>
<b>B</b>	<b>5 - Swashplate bearings</b>	
<b>C</b>	= Bushings	
	= Needle roller bearing	
	Attention: In case of displacement 21 cc with working pressure greater than or equal to 250 bar, select configuration B - SELF-LUBRICATING BUSHINGS	
<b>F1</b>	<b>6 - Mounting flange</b>	<b>21</b>
<b>F2</b>	= SAE-A 2 holes - pilot diam. 82,55 mm.	<b>21</b>
	= SAE-B 2 holes - pilot diam. 101,6 mm. (available only with servo-control)	<b>21</b>
<b>DM</b>	<b>7 - Pump controls</b>	
<b>BC</b>	= Direct mechanical (without control lever)	
<b>LC</b>	= Tapered bush	
<b>DMS</b>	= Direct Mechanical Control with Lever	
<b>DMS (30)</b>	= Control lever with return to zero position (torsion spring standard diameter 3,6 mm.)	
<b>DMS (33)</b>	= Control lever with return to zero position (torsion spring diameter 3 mm.)	
<b>DMS (44)</b>	= Control lever with return to zero position (torsion spring diameter 3,3 mm.)	
<b>DMS (50)</b>	= Control lever with return to zero position (torsion spring diameter 4 mm.)	
<b>DMZ</b>	= Control lever with return to zero position (torsion spring diameter 5 mm.)	
<b>SHI</b>	= Control lever with return to zero position (red compression spring)	
<b>SHIC</b>	= Integrated hydraulic servo control	
<b>SEI 1</b>	= Integrated hydraulic servo control (compact version)	
<b>SEI 2</b>	= Integrated electro-proportional servo control 12V DC	
<b>SEI 1 D</b>	= Integrated electro-proportional servo control 24V DC	
<b>SEI 2 D</b>	= Integrated electro-proportional servo control 12V DC DEUTSCH	
	= Integrated electro-proportional servo control 24V DC DEUTSCH	

F1	F2
X	
X	
X	
X	
X	
X	
X	
X	X
X	X
X	X
X	X
X	X

(continued)

**ORDER CODE**

39

**8 - Control devices position** (pump seen from the front on the drive shaft side)

- OA** = Upper position
- OB** = Lower position
- Device control LC, DMS e DMZ
- LA** = Left lever upper position
- LB** = Left lever lower position
- RA** = Right lever upper position
- RB** = Right lever lower position
- Device control SHI - SEI (all)
- OAL** = Upper servo position, left zero screw (STD)
- OBL** = Lower servo position, left zero screw
- OAR** = Upper servo position, right zero screw
- OBR** = Lower servo position, right zero screw

	OA	OB	LA	LB	RA	RB	OAL	OBL	OAR	OBR
DM	X	X								
BC	X	X								
LC			X	X	X	X				
DMS			X	X	X	X				
DMZ			X	X	X	X				
SHI							X	X	X	X
SEI							X	X	X	X

**9 - Relief valve pressure setting**

- 10** = 10 MPa                      **15** = 15 MPa                      **18** = 18 MPa
- 20** = 20 MPa                      **25** = 25 MPa                      **30** = 30 MPa
- 35** = 35 MPa

**10 - Boost pump**

- 00 (yy)** = Without boost pump [indicate flow rate (yy)]
- 06** = Boost pump STD C-B1-B2 (5,4 cm<sup>3</sup>/rev)
- For pressures other than STD, required between 0.5 MPa and 3 MPa MAX (calibration carried out at 1000 rpm).
- If in doubt contact our technical department.

**11 - Boost pressure**

- 05** = 0.5 MPa      **06** = 0.6 MPa (1)      **07** = 0.7 MPa      **08** = 0.8 MPa      **09** = 0.9 MPa
- 10** = 1.0 MPa      **11** = 1.1 MPa      **12** = 1.2 MPa      **13** = 1.3 MPa      **14** = 1.4 MPa
- 15** = 1.5 MPa      **16** = 1.6 MPa      **17** = 1.7 MPa      **18** = 1.8 MPa      **19** = 1.9 MPa
- 20** = 2.0 MPa (2)      **21** = 2.1 MPa      **22** = 2.2 MPa      **23** = 2.3 MPa      **24** = 2.4 MPa
- 25** = 2.5 MPa      **26** = 2.6 MPa      **27** = 2.7 MPa      **28** = 2.8 MPa      **29** = 2.9 MPa
- 30** = 3.0 MPa

	00	06
		5,4
C	X	X
B1	X	X
B2	X	X

Note: Boost pressures are recorded at 1000 n/min  
 Note 1: STD for DM-BC-LC-DMS-DMZ control pumps  
 Note 2: STD for SHI-SEI control pumps

**12 - Boost flow rating**

- 000** = Like boost pump      **030** = 3 l/min      **035** = 3,5 l/min      **040** = 4 l/min
- 045** = 4,5 l/min      **050** = 5 l/min      **055** = 5,5 l/min      **060** = 6 l/min
- 065** = 6,5 l/min      **070** = 7 l/min      **075** = 7,5 l/min      **080** = 8 l/min
- 085** = 8,5 l/min      **090** = 9 l/min      **095** = 9,5 l/min      **100** = 10 l/min
- 110** = 11 l/min      **120** = 12 l/min      **130** = 13 l/min      **140** = 14 l/min
- 150** = 15 l/min      **160** = 16 l/min      **170** = 17 l/min      **180** = 18 l/min
- 190** = 19 l/min      **200** = 20 l/min      **210** = 21 l/min      **220** = 22 l/min
- 230** = 23 l/min      **240** = 24 l/min      **250** = 25 l/min      **260** = 26 l/min
- 270** = 27 l/min      **280** = 28 l/min      **290** = 29 l/min      **300** = 30 l/min
- 310** = 31 l/min      **320** = 32 l/min      **330** = 33 l/min      **340** = 34 l/min

WARNING: For red flow rate, contact our technical department.

**13 - Cover/rear mounting flange**

- C** = Closed cover
- B1** = For German standard pump GR1 mounting (pilot flange ø32)
- B2** = For German standard pump GR2 mounting (pilot flange ø52)

41  
41  
41

(continued)

**ORDER CODE**

**14 - Gear pump displacements** (also available multiple gear pumps e.g. 204+117)

**Group 1**

<b>112</b> = 1,2 cm <sup>3</sup> /n	<b>117</b> = 1,7 cm <sup>3</sup> /n	<b>122</b> = 2,1 cm <sup>3</sup> /n	<b>126</b> = 2,6 cm <sup>3</sup> /n
<b>132</b> = 3,1 cm <sup>3</sup> /n	<b>138</b> = 3,6 cm <sup>3</sup> /n	<b>143</b> = 4,2 cm <sup>3</sup> /n	<b>149</b> = 4,9 cm <sup>3</sup> /n
<b>159</b> = 5,9 cm <sup>3</sup> /n	<b>165</b> = 6,5 cm <sup>3</sup> /n	<b>178</b> = 7,5 cm <sup>3</sup> /n	

**Group 2**

<b>204</b> = 4,2 cm <sup>3</sup> /n	<b>206</b> = 6,0 cm <sup>3</sup> /n	<b>209</b> = 8,4 cm <sup>3</sup> /n	<b>211</b> = 10,8 cm <sup>3</sup> /n
<b>214</b> = 14,4 cm <sup>3</sup> /n	<b>217</b> = 16,8 cm <sup>3</sup> /n	<b>219</b> = 19,2 cm <sup>3</sup> /n	<b>222</b> = 22,8 cm <sup>3</sup> /n
<b>226</b> = 26,2 cm <sup>3</sup> /n			

**15 - Gear pumps connections**

<b>0</b>	= Without gear pump	<b>42</b>
<b>F</b>	= Connection with holes for flange	<b>42</b>
<b>G</b>	= Connection with GAS holes (BSPP)	<b>42</b>

Attention: For GR 1 pumps, GAS ports is standard; for GR 2 pumps flanged is standard

**16 - Optional**

<b>00</b>	= Without optional	<b>43</b>
<b>FB</b>	= Conversion flange from SAE-A to SAE-B	<b>43</b>
<b>ST</b>	= Conversion coupling from 9 teeth to 13 teeth	<b>43</b>
<b>VS</b>	= Flushing valve	<b>44</b>
<b>SB</b>	= Screw by-pass	<b>46</b>
<b>SB (0.8)</b>	= Perforated screw by-pass ø0.8 for DMS control pumps	
<b>SB1</b>	= Screw by-pass (rotated position of 180° - lower)	<b>47</b>
<b>SB1 (0.8)</b>	= Perforated screw by-pass ø0.8 for DMS control pumps (rotated position of 180° - lower)	
<b>FBST</b>	= Conversion flange from SAE-A to SAE-B + Conversion shaft 9 teeth to 13 teeth	<b>48</b>
<b>MOB</b>	= Man On Board (only SHI and SEI versions)	<b>49</b>

**17 - Ports**

Combination		S	A-B	T-T1	P1-P2	Ma-Mb	IN-OUT	G
		Suction	Ports	Tanks	Pilot	Pressure connection	Remote filter connection	Suction pressure connection
<b>G</b>	GAS Ports (STD)	1/2" BSPP	1/2" BSPP	1/2" BSPP	1/4" BSPP	1/4" BSPP	3/8" BSPP	1/4" BSPP
<b>U</b>	UNF Ports (1)	7/8-14 UNF	7/8-14 UNF	7/8-14 UNF	9/16-18 UNF	9/16-18 UNF	7/8-14 UNF	9/16-18 UNF

Note 1: only on request and minimum quantity of 50 pieces.

**18 - Restrictor on servo control** (only SHI and SEI versions)

<b>00</b>	= Without restrictor
<b>06</b>	= Restrictor orifice ø0,6 mm
<b>07</b>	= Restrictor orifice ø0,7 mm
<b>08</b>	= Restrictor orifice ø0,8 mm
<b>10</b>	= Restrictor orifice ø1,0 mm
<b>12</b>	= Restrictor orifice ø1,2 mm

**TANDEM PUMP**

(Direct mechanical control - overall dimensions)

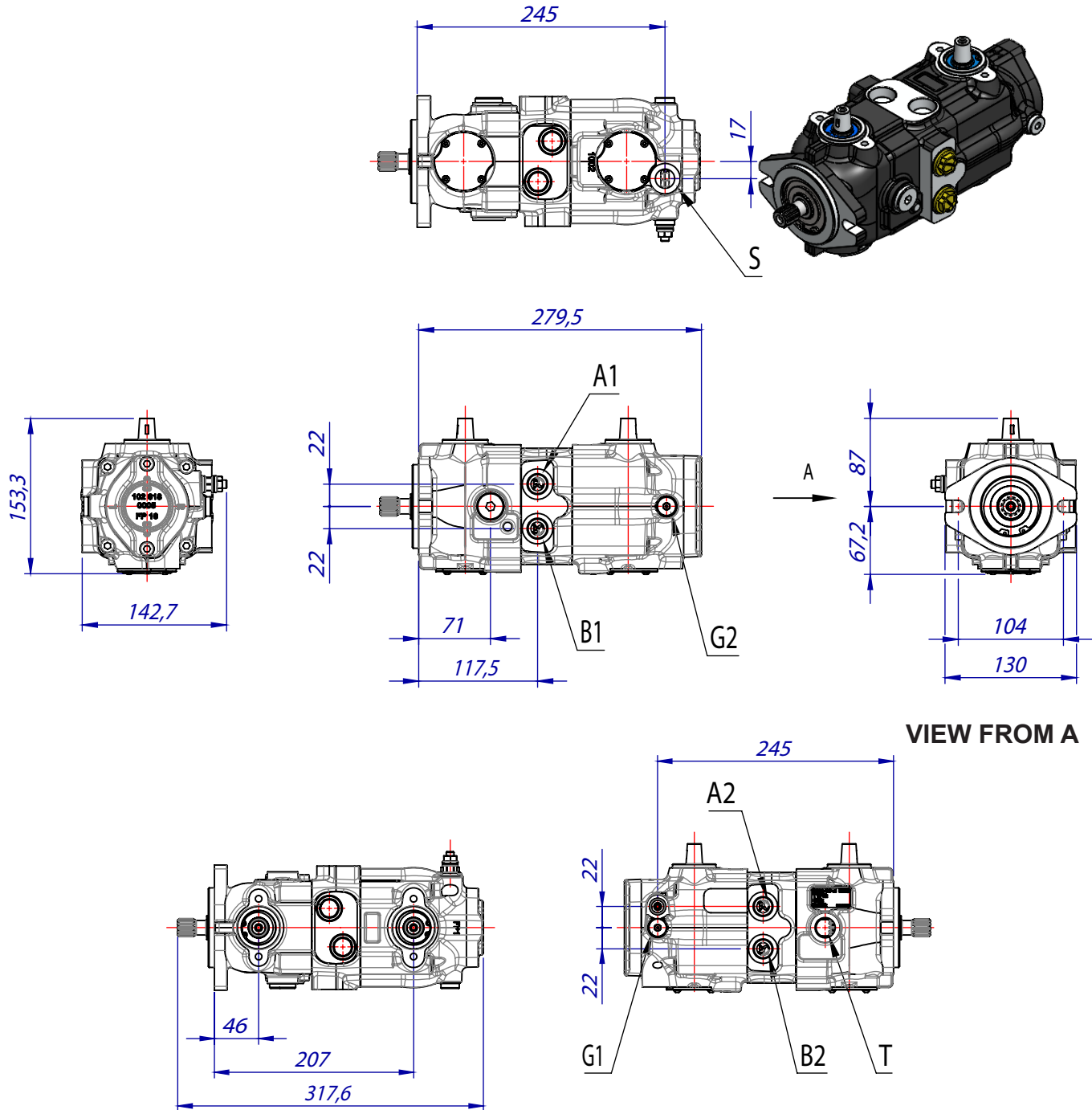

PIPES CONNECTION		
REFERENCE	DESCRIPTION	F1 - SAE A
A1 - B1	Main ports pump 1	1/2" BSPP
A2 - B2	Main ports pump 2	1/2" BSPP
T	Drain	1/2" BSPP
S	Suction	1/2" BSPP
G1 - G2	Boost pump pressure gauge ports	1/4" BSPP

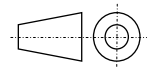

**PUMP WITH SHI - HYDRAULIC SERVO CONTROL**  
(overall dimensions)

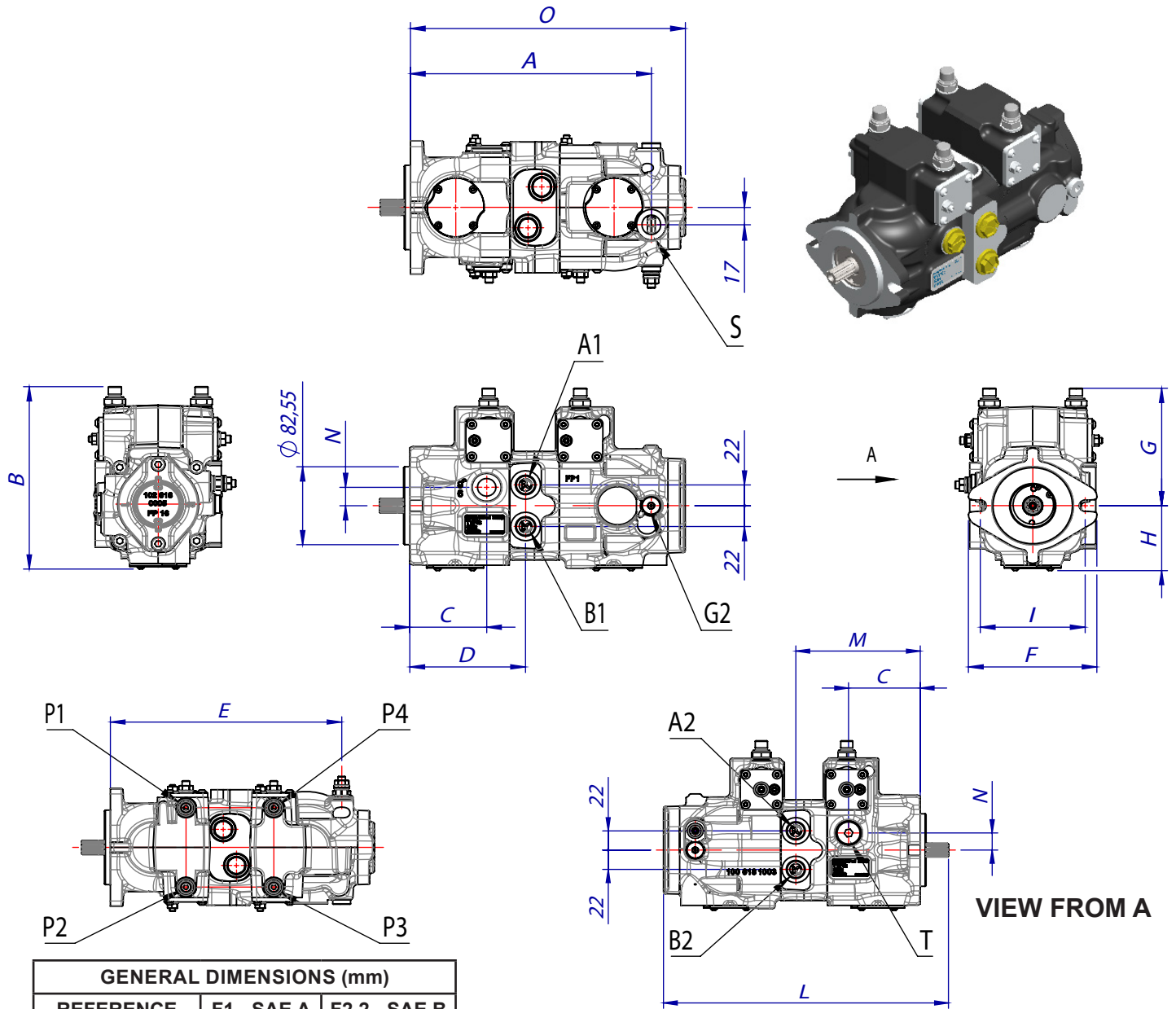

GENERAL DIMENSIONS (mm)		
REFERENCE	F1 - SAE A	F2.2 - SAE B
A	245	246
B	193,2	190,2
C	78	79
D	117,5	118,5
E	245	246
F	130,4	174,6
G	124,5	121,5
H	68,7	68,7
I	106,4	146
L	310,2	320,5
M	135,5	136,5
N	19,5	19,5
O	279,5	280,5

PIPES CONNECTION			
REFERENCE	DESCRIPTION	F1 - SAE A	F2.2 - SAE B
A1 - B1	Main ports pump 1	1/2" BSPP	1/2" BSPP
A2 - B2	Main ports pump 2	1/2" BSPP	1/2" BSPP
T1 - T2	Drain	1/2" BSPP	1/2" BSPP
S	Suction	1/2" BSPP	1/2" BSPP
G1 - G2	Boost pump pressure gauge ports	1/4" BSPP	1/4" BSPP
P1 - P2	Pilot pressure pump 1	1/4" BSPP	1/4" BSPP
P3 - P4	Pilot pressure pump 2	1/4" BSPP	1/4" BSPP

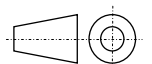

**PUMP WITH SEI - ELECTRO-PROPORTIONAL SERVO CONTROL**  
(overall dimensions)

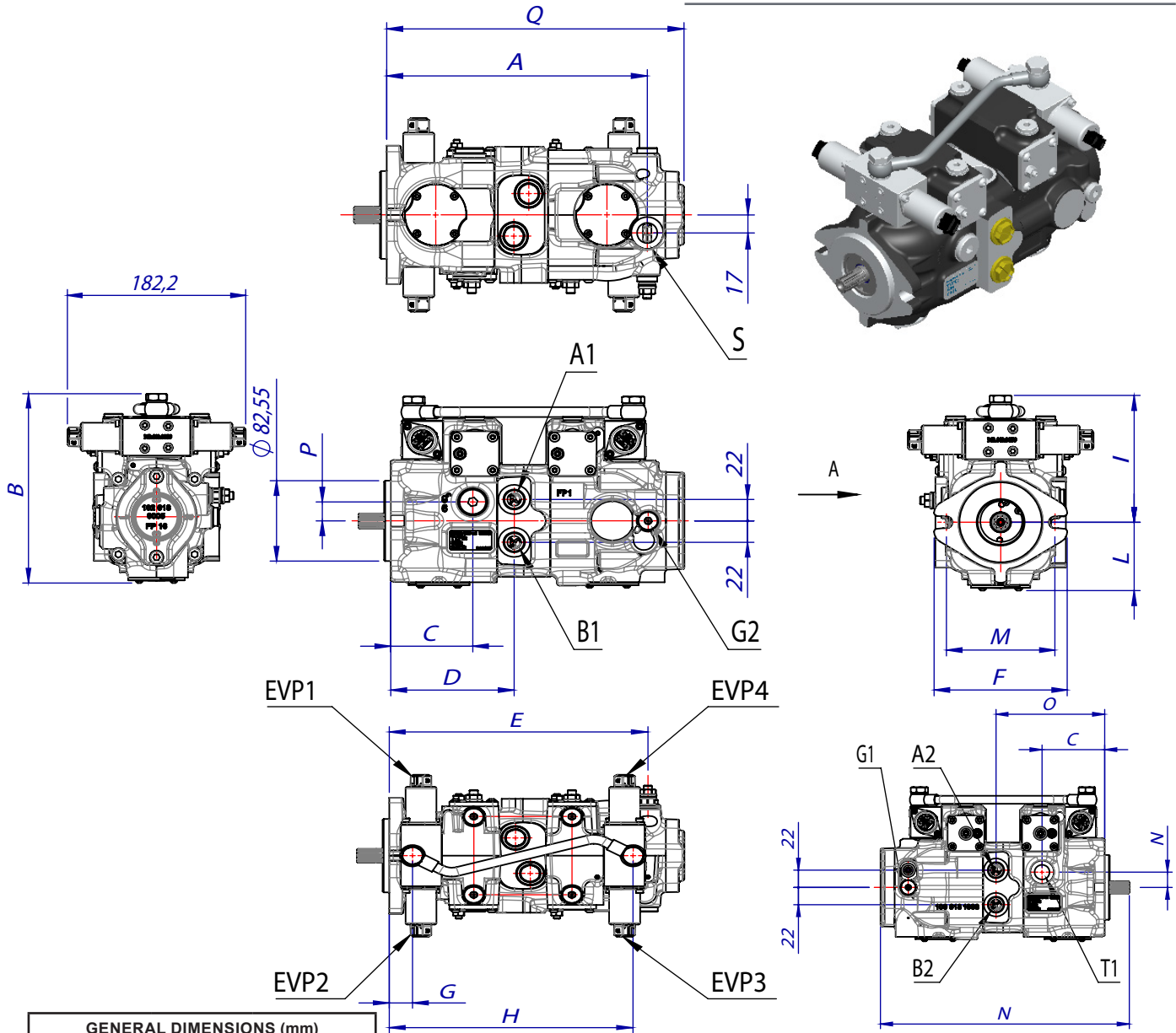

VIEW FROM A

GENERAL DIMENSIONS (mm)		
REFERENCE	F1 - SAE A	F2.2 - SAE B
A	245	246
B	192,5	196,5
C	78	79
D	117,5	118,5
E	245	246
F	130	174,6
G	22	23
H	231	232
I	126,3	127,8
L	66,2	68,7
M	104	146
N	310,2	320,5
O	135,5	136,5
P	0	19,5
Q	279,5	280,5

PIPES CONNECTION			
REFERENCE	DESCRIPTION	F1 - SAE A	F2.2 - SAE B
A1 - B1	Main ports pump 1	1/2" BSPP	1/2" BSPP
A2 - B2	Main ports pump 2	1/2" BSPP	1/2" BSPP
T1 - T2	Drain	1/2" BSPP	1/2" BSPP
S	Suction	1/2" BSPP	1/2" BSPP
G1 - G2	Boost pump pressure gauge ports	1/4" BSPP	1/4" BSPP



**MOUNTING FLANGES AND SHAFT**

**PS3**

**PARALLEL KEYED SHAFT**

Diam. 18 mm.

Max. torque = 85 Nm

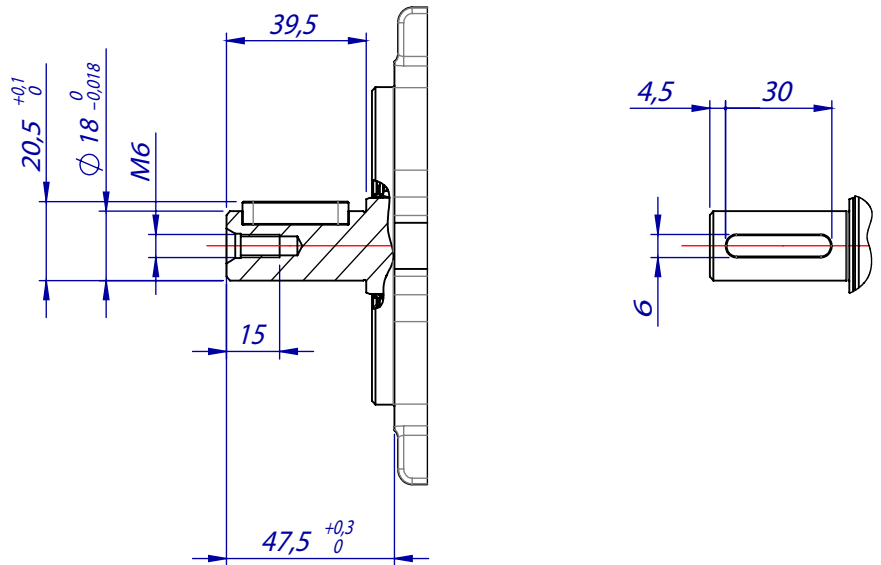

**SS2**

**SPLINED SHAFT 16/32 DP**

ANSI standard B92.2-1970 CLASS 5

Max. torque = 120 Nm

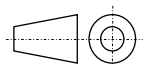
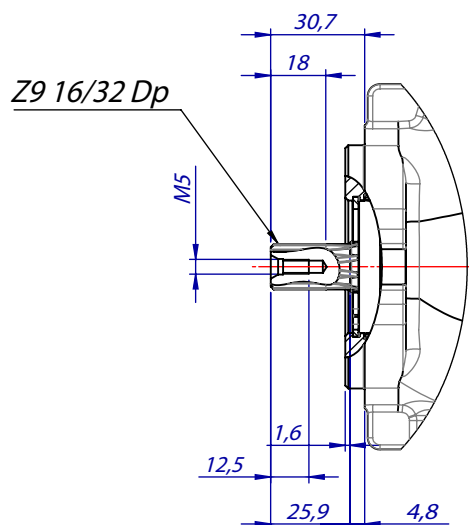

(continued)

**MOUNTING FLANGES AND SHAFT**

**SS3**

**SPLINED SHAFT Z = 13 16/32 DP**

ANSI standard B92.2-1970 CLASS 5

Max. torque = 320 Nm

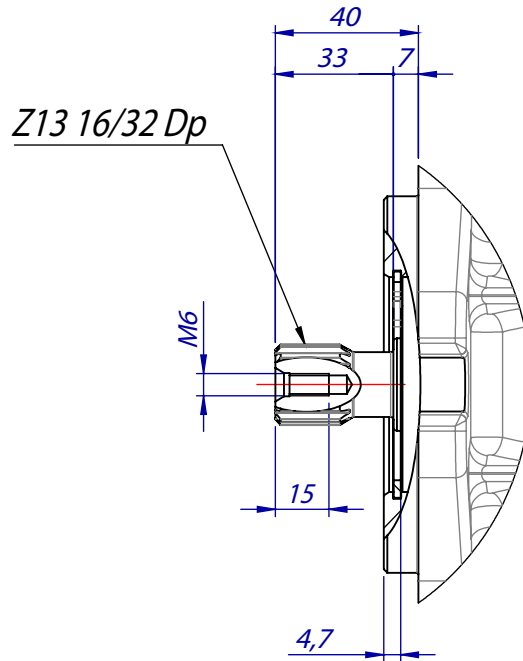

**SS4**

**SPLINED SHAFT Z = 11 16/32 DP**

ANSI standard B92.2-1970 CLASS 5

Max. torque = 160 Nm

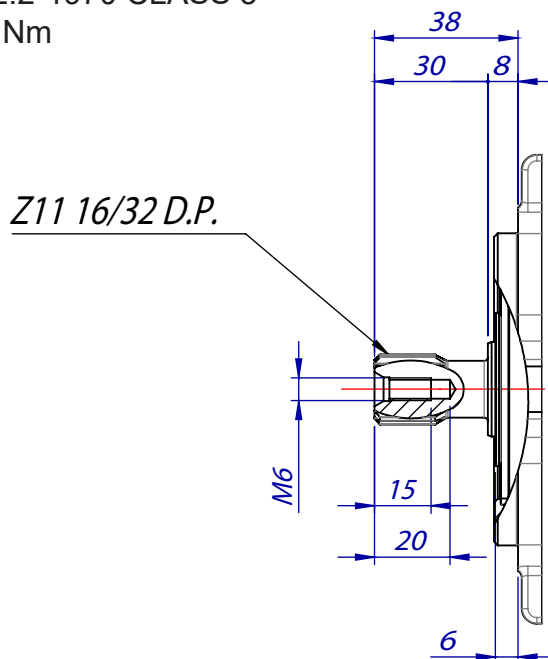

**Attention:** For the application of multiple pumps the total absorbed torque must not exceed the indicated value.

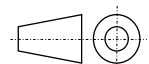



(continued)

**MOUNTING FLANGES AND SHAFT**

**F1**

**SAE A - 2 HOLES FLANGE**

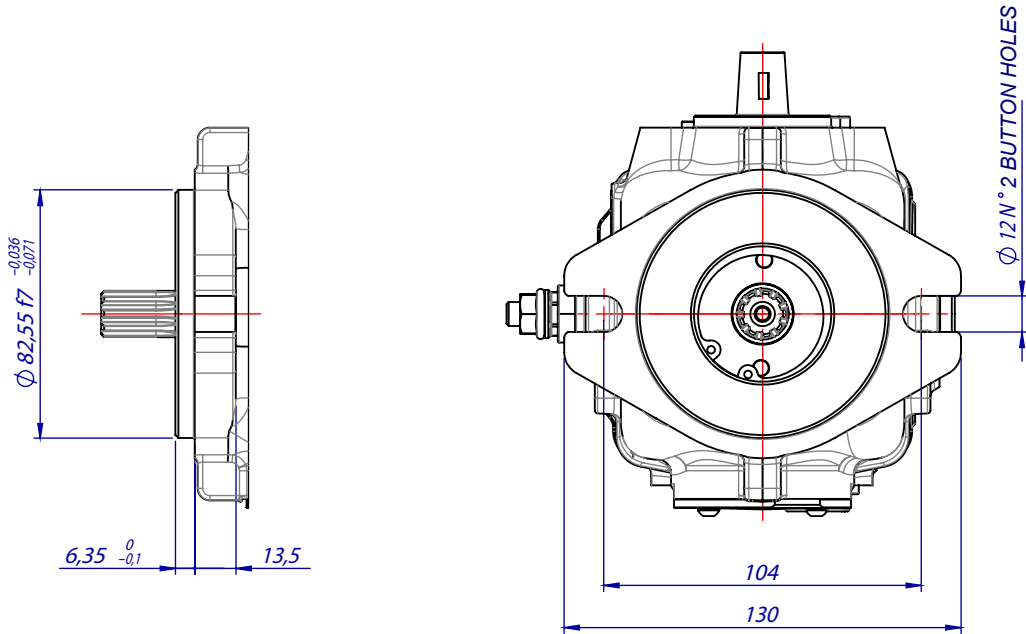

**F2**

**SAE B - 2 HOLES FLANGE**

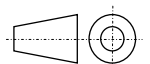
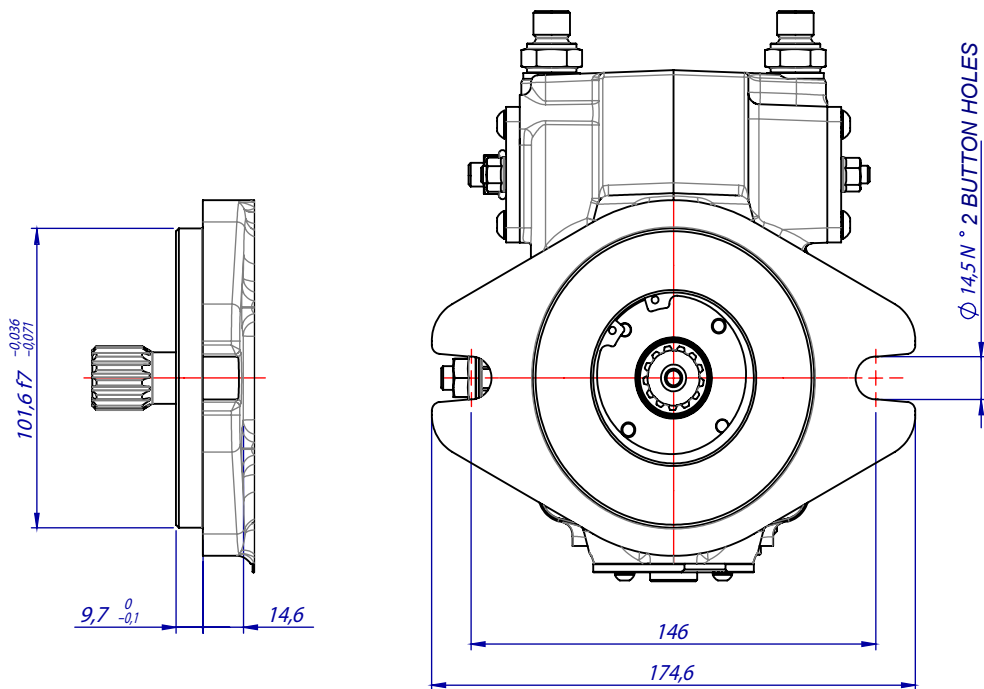

**DM**

**DIRECT MECHANICAL CONTROL**

The change of pump displacement is given by clockwise or conter clockwise rotation of the drive pin of the oscillating plate.

The control's pivot is directly connected to the pump swashplate.

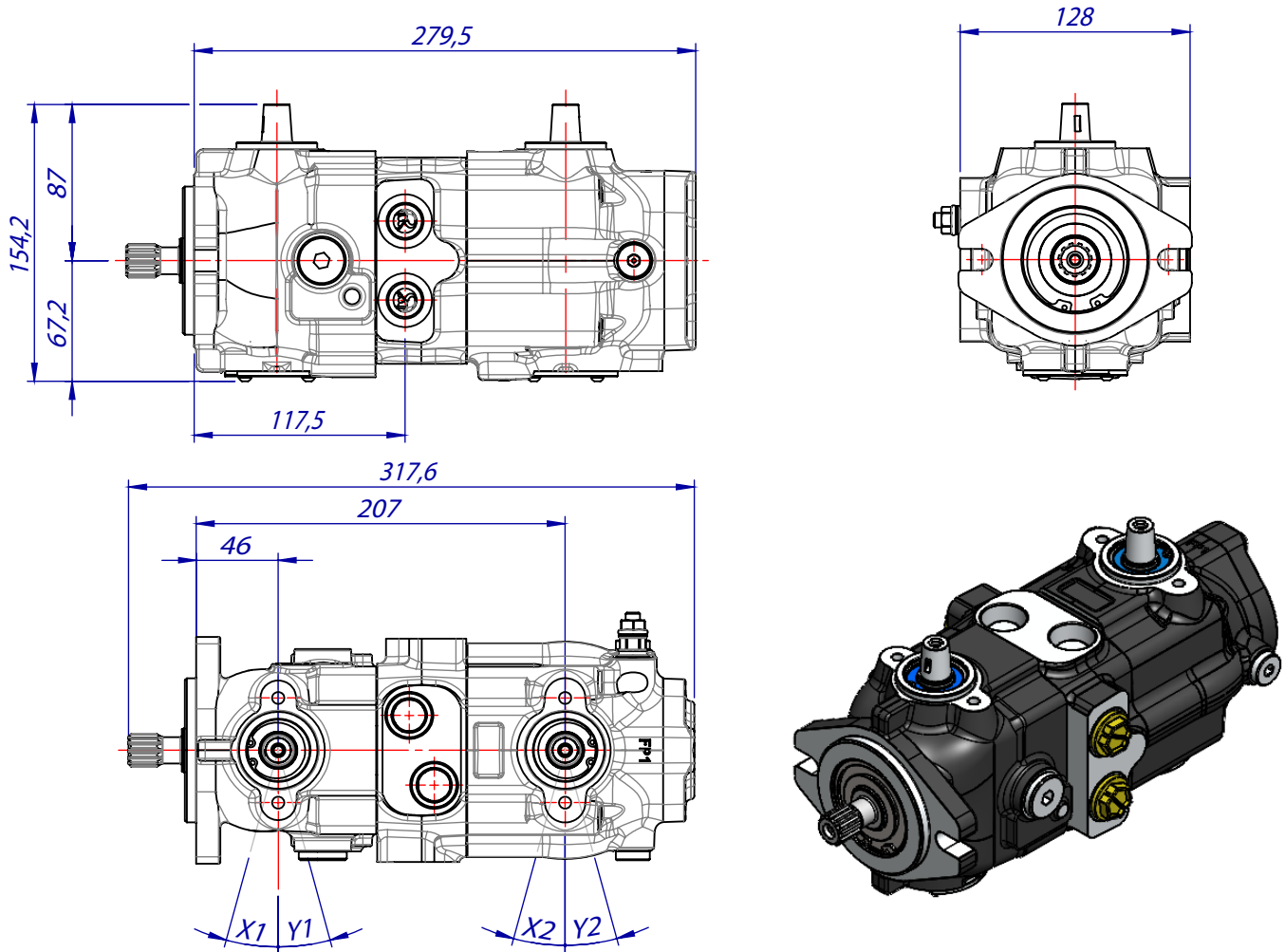

LEVER ANGLE											
Pump Model	6/7	8/7	9/7	11/7	12/7	13/7	15/9	17/9	18/9	19/9	21/9
Lever Angle (X - Y)	10°	12°	13°	15°	17°	18°	15°	17°	18°	19°	19°

(continued)

**DM**

**DIRECT MECHANICAL CONTROL**

**HYDRAULIC CIRCUIT**

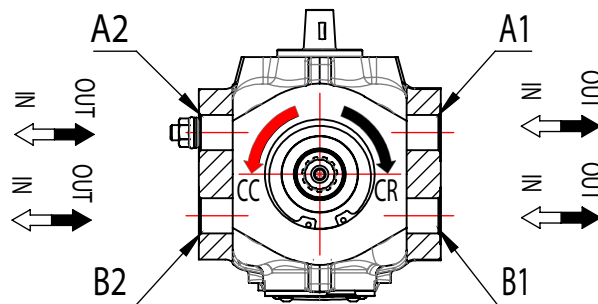
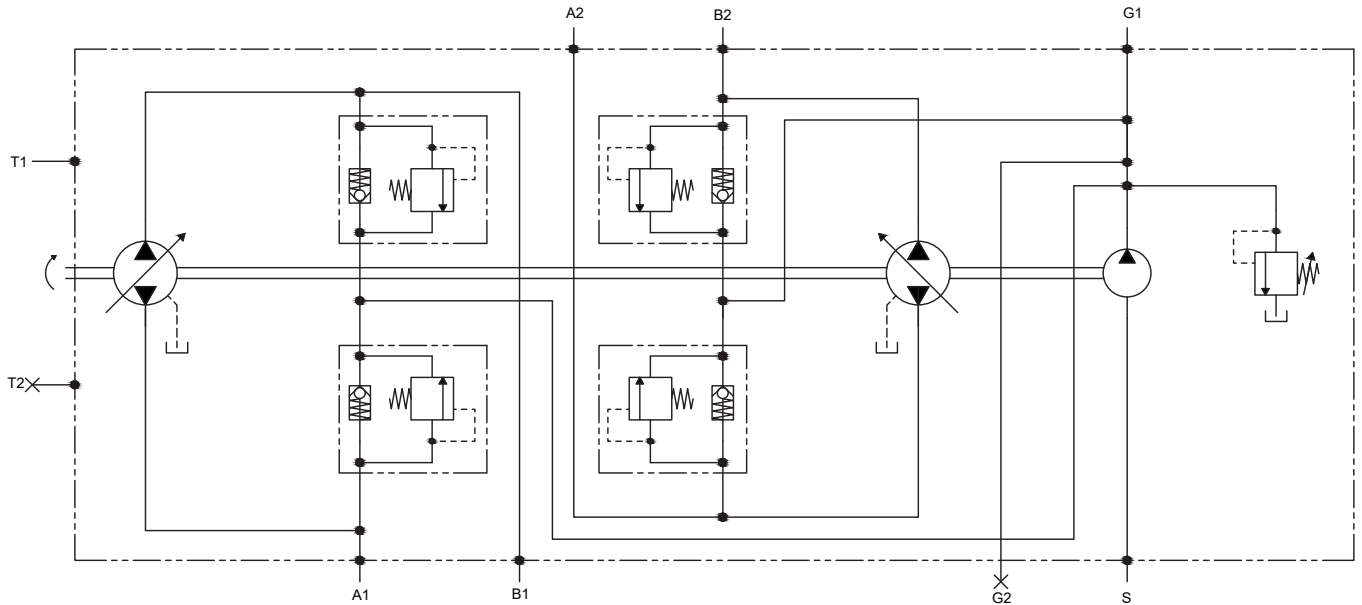

FLOW DIRECTION	PRIMARY PUMP			SECONDARY PUMP		
	Lever position	OUT	IN	Lever position	OUT	IN
Clockwise (CR)	X <sub>1</sub>	B <sub>1</sub>	A <sub>1</sub>	X <sub>2</sub>	A <sub>2</sub>	B <sub>2</sub>
	Y <sub>1</sub>	A <sub>1</sub>	B <sub>1</sub>	Y <sub>2</sub>	B <sub>2</sub>	A <sub>2</sub>
Counter clockwise (CC)	X <sub>1</sub>	A <sub>1</sub>	B <sub>1</sub>	X <sub>2</sub>	B <sub>2</sub>	A <sub>2</sub>
	Y <sub>1</sub>	B <sub>1</sub>	A <sub>1</sub>	Y <sub>2</sub>	A <sub>2</sub>	B <sub>2</sub>

# BC

## TAPERED BUSH

Tapered bush with Woodruff key UNI 6606, external cylindric. Suitable for arrangement of specific control lever.

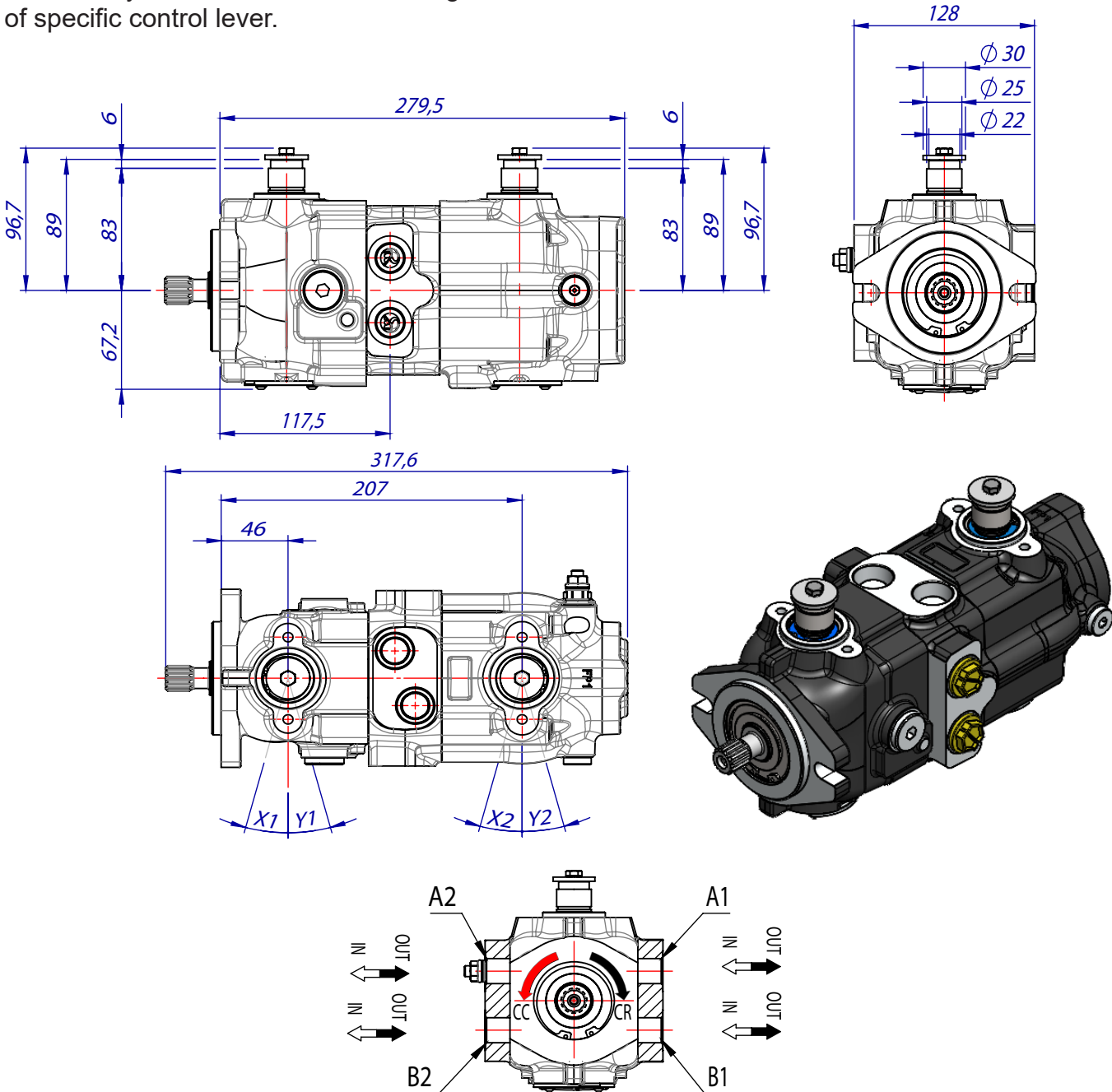

FLOW DIRECTION	PRIMARY PUMP			SECONDARY PUMP		
	Lever position	OUT	IN	Lever position	OUT	IN
Clockwise (CR)	X <sub>1</sub>	B <sub>1</sub>	A <sub>1</sub>	X <sub>2</sub>	A <sub>2</sub>	B <sub>2</sub>
	Y <sub>1</sub>	A <sub>1</sub>	B <sub>1</sub>	Y <sub>2</sub>	B <sub>2</sub>	A <sub>2</sub>
Counter clockwise (CC)	X <sub>1</sub>	A <sub>1</sub>	B <sub>1</sub>	X <sub>2</sub>	B <sub>2</sub>	A <sub>2</sub>
	Y <sub>1</sub>	B <sub>1</sub>	A <sub>1</sub>	Y <sub>2</sub>	A <sub>2</sub>	B <sub>2</sub>

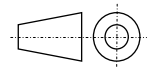

# LC

## DIRECT MECHANICAL CONTROL WITH LEVER

The pump displacement variation is obtained by rotating the lever in a clockwise or counter-clockwise direction. The control's pivot is directly connected to the pump swashplate.

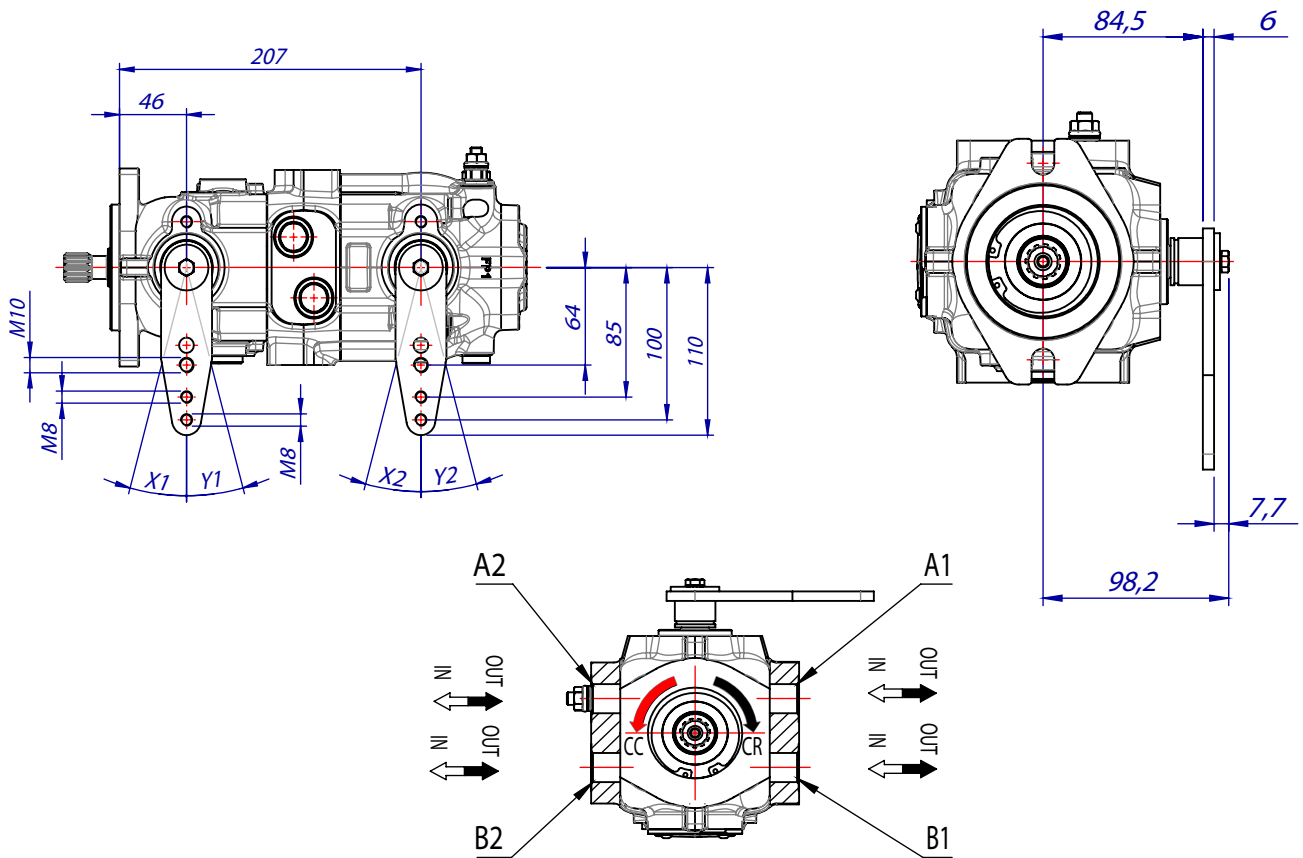
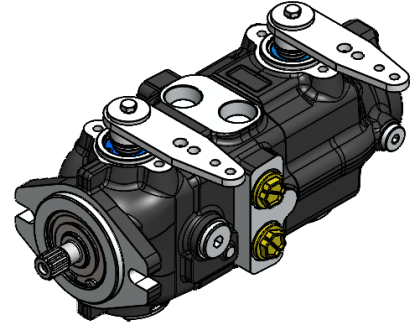

LEVER ANGLE											
Pump Model	6/7	8/7	9/7	11/7	12/7	13/7	15/9	17/9	18/9	19/9	21/9
Lever Angle (X - Y)	10°	12°	13°	15°	17°	18°	15°	17°	18°	19°	19°

FLOW DIRECTION	PRIMARY PUMP			SECONDARY PUMP		
	Lever position	OUT	IN	Lever position	OUT	IN
Clockwise (CR)	X <sub>1</sub>	B <sub>1</sub>	A <sub>1</sub>	X <sub>2</sub>	A <sub>2</sub>	B <sub>2</sub>
	Y <sub>1</sub>	A <sub>1</sub>	B <sub>1</sub>	Y <sub>2</sub>	B <sub>2</sub>	A <sub>2</sub>
Counter clockwise (CC)	X <sub>1</sub>	A <sub>1</sub>	B <sub>1</sub>	X <sub>2</sub>	B <sub>2</sub>	A <sub>2</sub>
	Y <sub>1</sub>	B <sub>1</sub>	A <sub>1</sub>	Y <sub>2</sub>	A <sub>2</sub>	B <sub>2</sub>

# DMS

## CONTROL LEVER WITH RETURN TO ZERO FLOW POSITION

(torsion spring)

The pump displacement variation is obtained by rotating the lever in a clockwise or counter-clockwise direction.

Return to zero is obtained through a spring integrated in the lever shaft.

The control's pivot is directly connected to the pump swashplate.

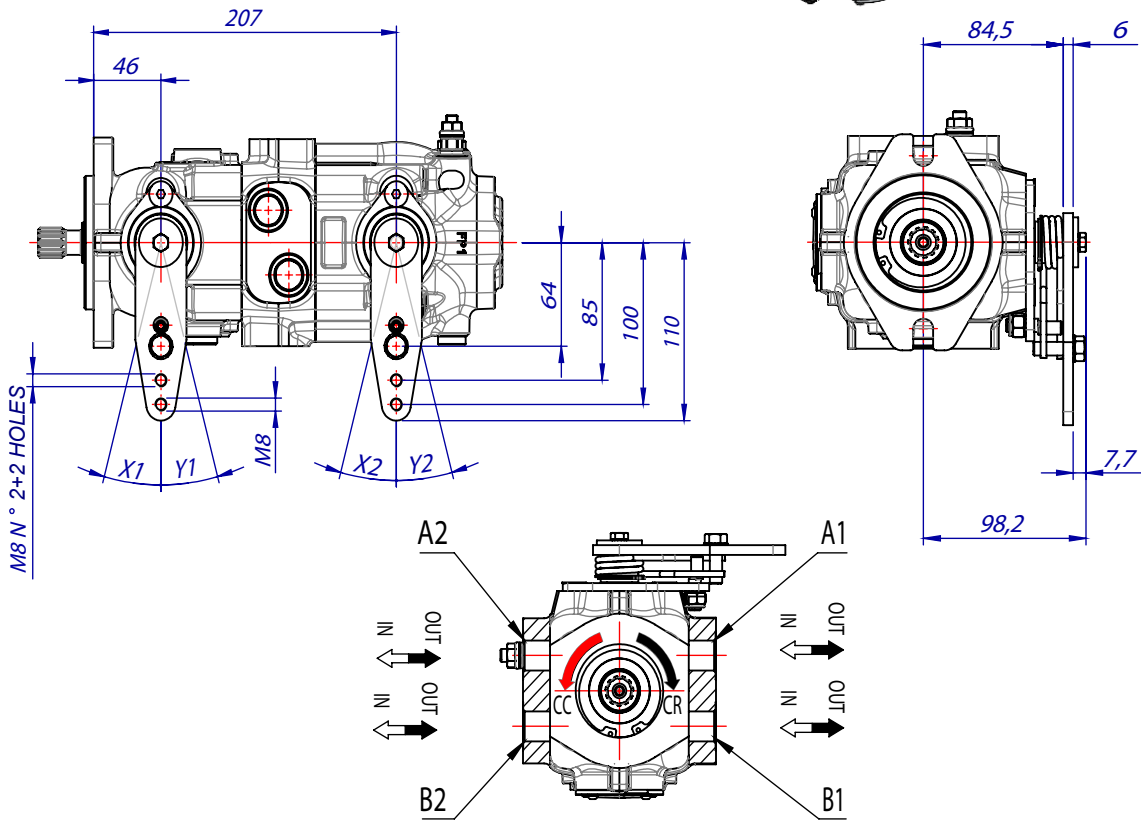
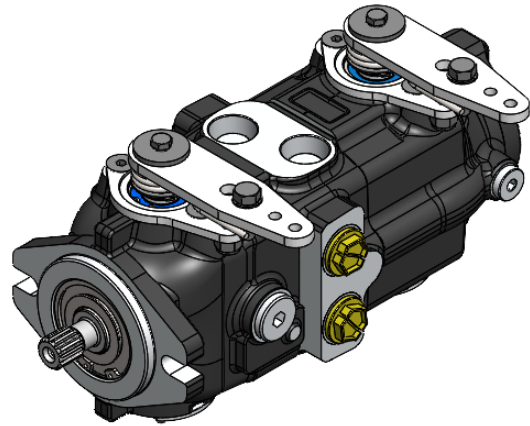

FLOW DIRECTION	PRIMARY PUMP			SECONDARY PUMP		
	Lever position	OUT	IN	Lever position	OUT	IN
Clockwise (CR)	X <sub>1</sub>	B <sub>1</sub>	A <sub>1</sub>	X <sub>2</sub>	A <sub>2</sub>	B <sub>2</sub>
	Y <sub>1</sub>	A <sub>1</sub>	B <sub>1</sub>	Y <sub>2</sub>	B <sub>2</sub>	A <sub>2</sub>
Counter clockwise (CC)	X <sub>1</sub>	A <sub>1</sub>	B <sub>1</sub>	X <sub>2</sub>	B <sub>2</sub>	A <sub>2</sub>
	Y <sub>1</sub>	B <sub>1</sub>	A <sub>1</sub>	Y <sub>2</sub>	A <sub>2</sub>	B <sub>2</sub>

LEVER ANGLE											
Pump Model	6/7	8/7	9/7	11/7	12/7	13/7	15/9	17/9	18/9	19/9	21/9
Lever Angle (X - Y)	10°	12°	13°	15°	17°	18°	15°	17°	18°	19°	19°



(continued)

# DMS

## CONTROL LEVER WITH RETURN TO ZERO POSITION

(torsion spring)

Standard spring diameter: 3,6 mm

Other available diameters: 3 - 3,3 - 4 - 5

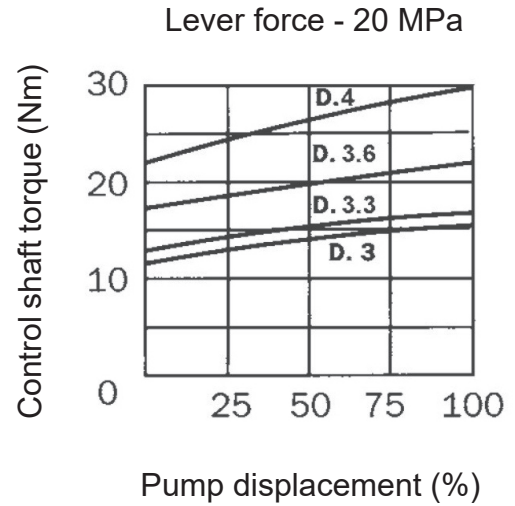
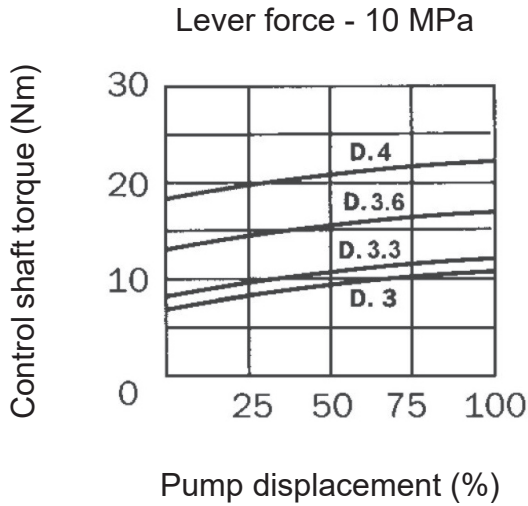

# DMZ

## CONTROL LEVER WITH RETURN TO ZERO POSITION

(compression spring)

The pump displacement variation is obtained by rotating the lever in a clockwise or counter-clockwise direction.

Return to zero is obtained through a spring integrated in the lever shaft. The control's pivot is directly connected to the pump swashplate.

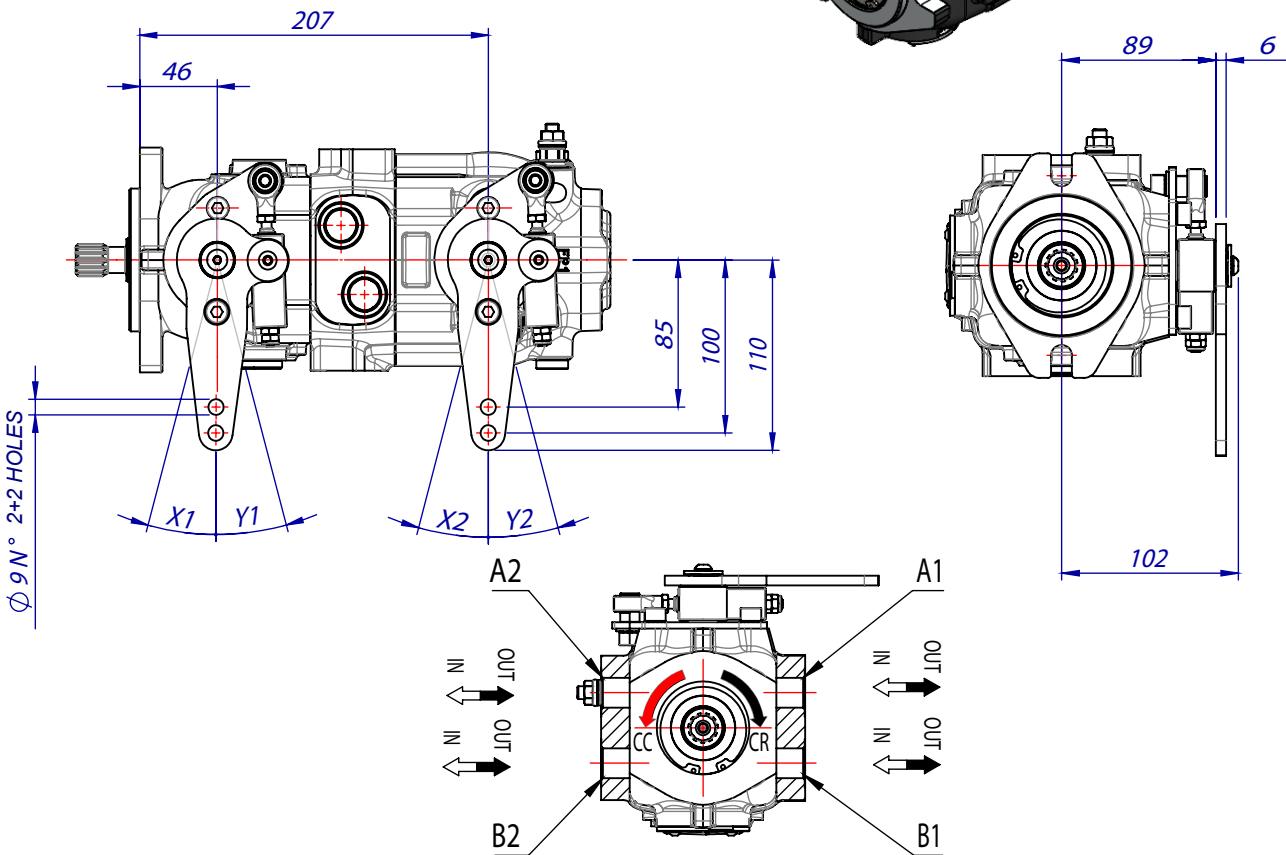
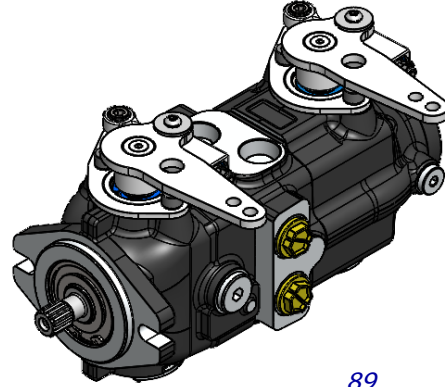

FLOW DIRECTION	PRIMARY PUMP			SECONDARY PUMP		
	Lever position	OUT	IN	Lever position	OUT	IN
Clockwise (CR)	$X_1$	$B_1$	$A_1$	$X_2$	$A_2$	$B_2$
	$Y_1$	$A_1$	$B_1$	$Y_2$	$B_2$	$A_2$
Counter clockwise (CC)	$X_1$	$A_1$	$B_1$	$X_2$	$B_2$	$A_2$
	$Y_1$	$B_1$	$A_1$	$Y_2$	$A_2$	$B_2$

LEVER ANGLE											
Pump Model	6/7	8/7	9/7	11/7	12/7	13/7	15/9	17/9	18/9	19/9	21/9
Lever Angle (X - Y)	10°	12°	13°	15°	17°	18°	15°	17°	18°	19°	19°





(continued)

# DMZ

## CONTROL LEVER WITH RETURN TO ZERO POSITION

(compression spring)

### HYDRAULIC CIRCUIT

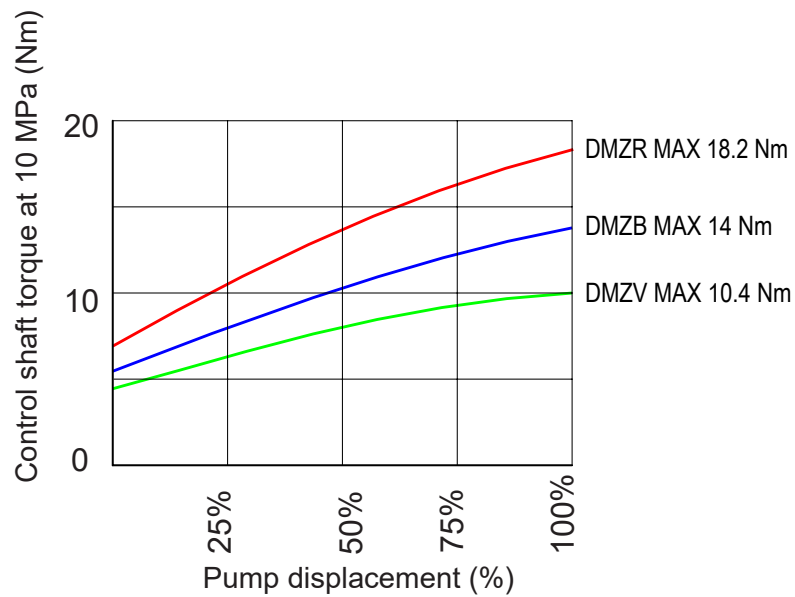
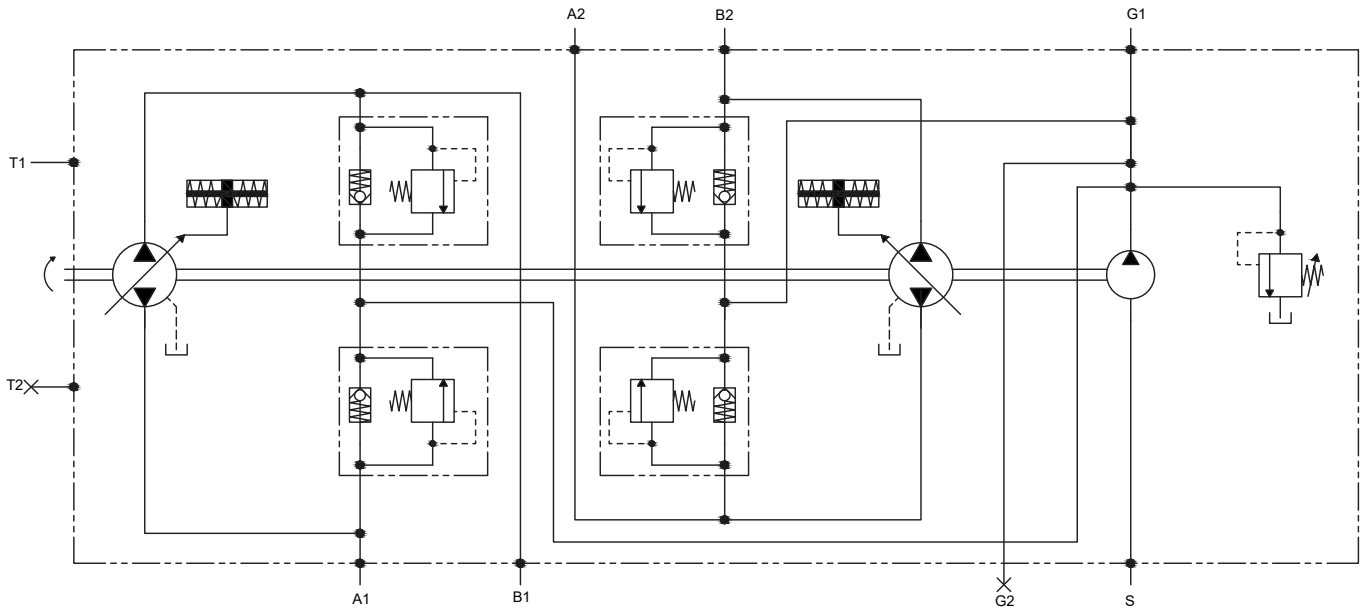

# SHI

## HYDRAULIC SERVO-CONTROL

The pump displacement variation is obtained by adjusting the pressure on P1, P2, P3 and P4 servo control ports by means of a hydraulic proportional joystick (with integrated pressure reducing valves).

The servo control supply can be obtained by taking pressure from the boost pump (G1-G2 ports). The servo control return line can be adjusted by inserting a restrictor on the

joystick supply line (0,5 ÷ 1,2 mm).

The servo control operation curve, in both directions, goes from 0,4 MPa to 1,8 MPa (tolerance ± 5 %).

The adjusting curve of the hydraulic joystick has to be a little wider (0,3 MPa ÷ 1,9 MPa).

Suggested curves for HPV series Joysticks: CR062 (see HT/73/B/105/0919/E catalogue).

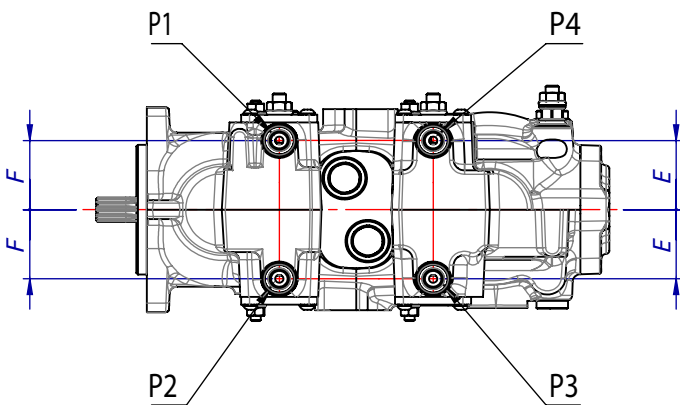
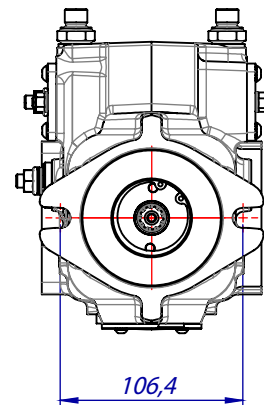
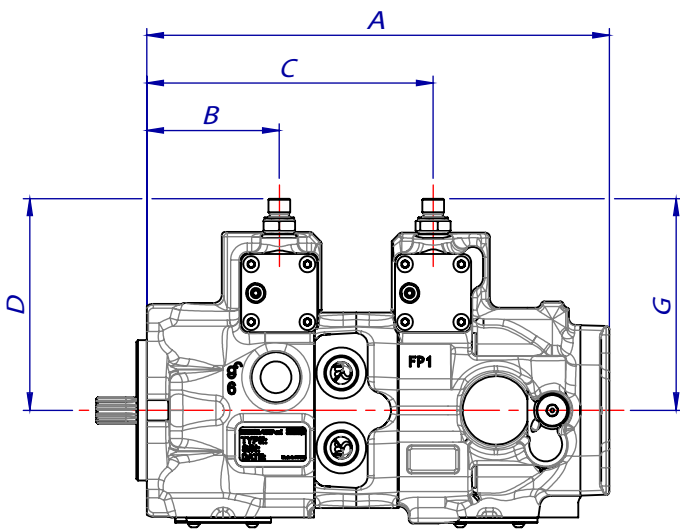

STANDARD CONNECTOR

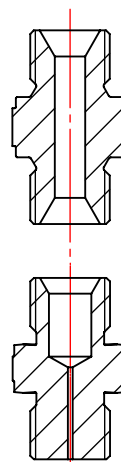

OPTIONAL RESTRICTOR ORIFICE.  
SEE POINT 18 ORDER CODE  
FOR AVAILABILITY DIAMETERS

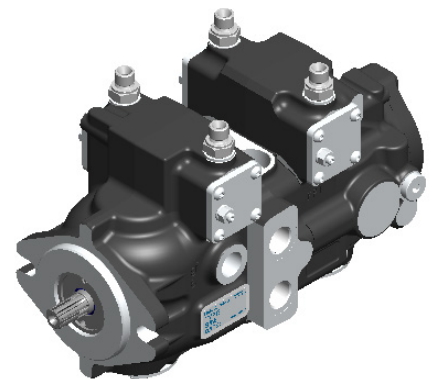

GENERAL DIMENSIONS (mm)		
REFERENCE	F1 - SAE A	F2.2 - SAE B
A	279,5	280,5
B	80	81
C	173	174
D	124,5	121,5
E	44	44
F	44	44
G	124,5	124,5

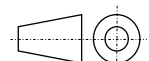

(continued)

**SHI**

**HYDRAULIC SERVO-CONTROL**

**HYDRAULIC CIRCUIT**

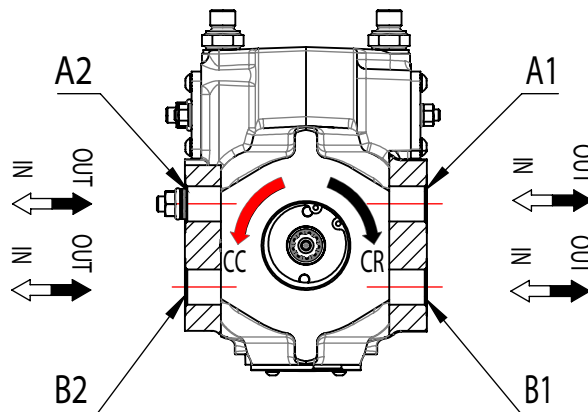
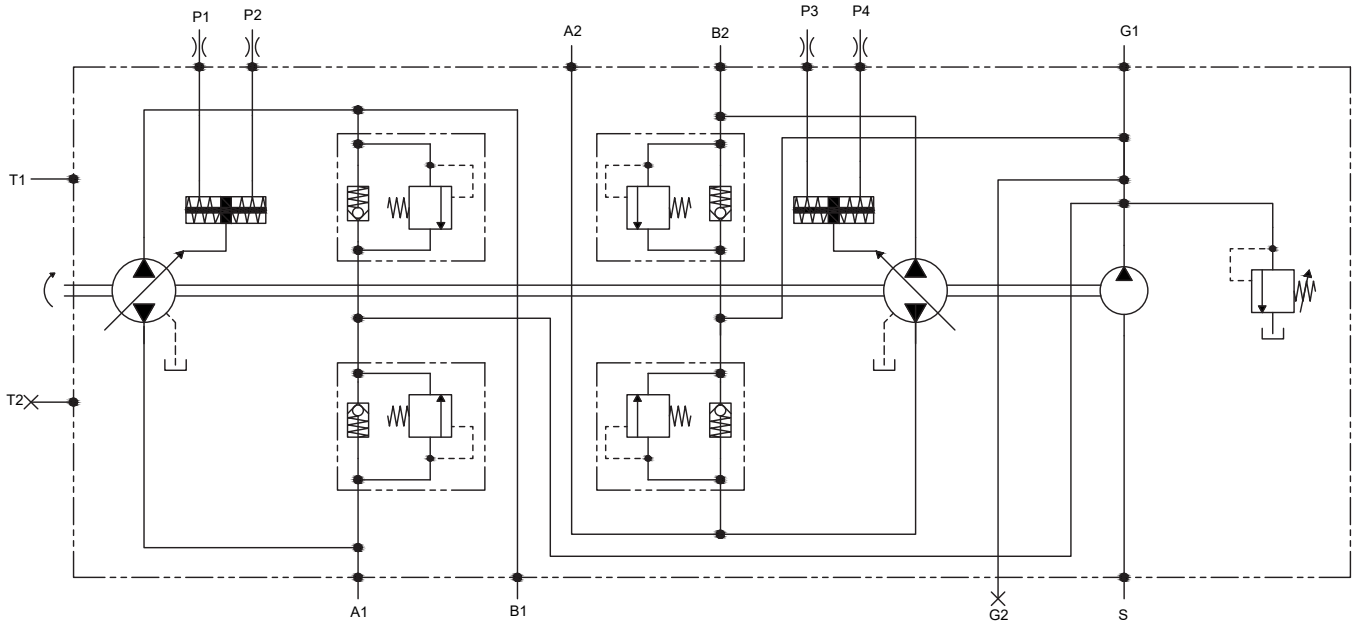

FLOW DIRECTION	PRIMARY PUMP			SECONDARY PUMP		
	Port	OUT	IN	Port	OUT	IN
Clockwise (CR)	P <sub>1</sub> P <sub>2</sub>	B <sub>1</sub> A <sub>1</sub>	A <sub>1</sub> B <sub>1</sub>	P <sub>3</sub> P <sub>4</sub>	A <sub>2</sub> B <sub>2</sub>	B <sub>2</sub> A <sub>2</sub>
Counter clockwise (CC)	P <sub>1</sub> P <sub>2</sub>	A <sub>1</sub> B <sub>1</sub>	B <sub>1</sub> A <sub>1</sub>	P <sub>3</sub> P <sub>4</sub>	B <sub>2</sub> A <sub>2</sub>	A <sub>2</sub> B <sub>2</sub>

# SHIC

## COMPACT HYDRAULIC CONTROL

(with side pilot ports)

The pump displacement variation is obtained by adjusting the pressure on P1, P2, P3 and P4 servo control ports by means of a hydraulic proportional joystick (with integrated pressure reducing valves). The servo control supply can be obtained by taking pressure from the boost pump (G1- G2 ports).

The servo control return time can be adjusted

by inserting a restrictor on the joystick supply line (0,5 ÷ 1,2 mm). The servo control operation curve, in both directions, goes from 0,4 MPa to 1,8 MPa (tolerance (± 5 %)).

The adjusting curve of the hydraulic joystick has to be a little wider (0,3 MPa ÷ 1,9 MPa).

Suggested curves for HPV series Joysticks: CR062 (see HT/73/B/105/0919/E catalogue).

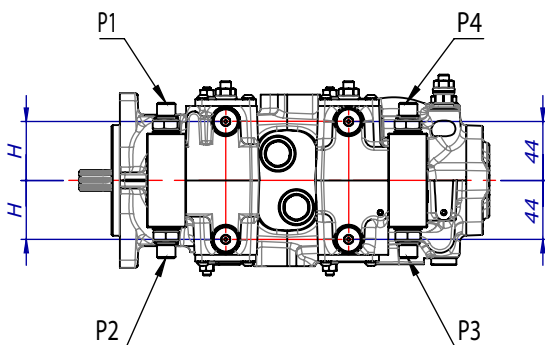
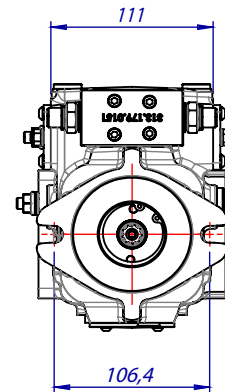
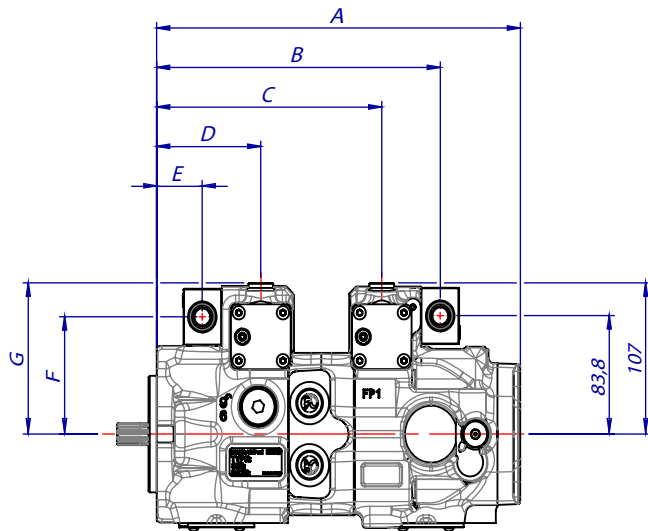

STANDARD CONNECTOR

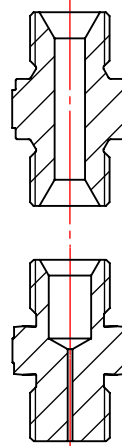

OPTIONAL RESTRICTOR ORIFICE.  
SEE POINT 18 ORDER CODE  
FOR AVAILABILITY DIAMETERS

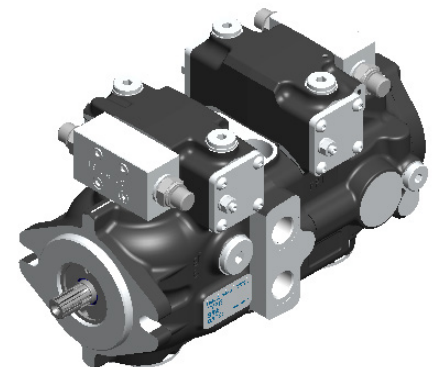

GENERAL DIMENSIONS (mm)		
REFERENCE	F1 - SAE A	F2 - SAE B
A	279,5	280,5
B	218	219
C	173	174
D	80	81
E	35	36
F	83	83
G	107	107
H	44	44



(continued)

**SHIC**

**COMPACT HYDRAULIC CONTROL**

(with side pilot ports)

**HYDRAULIC CIRCUIT**

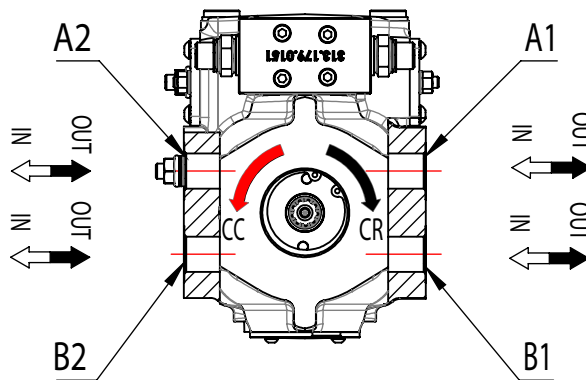
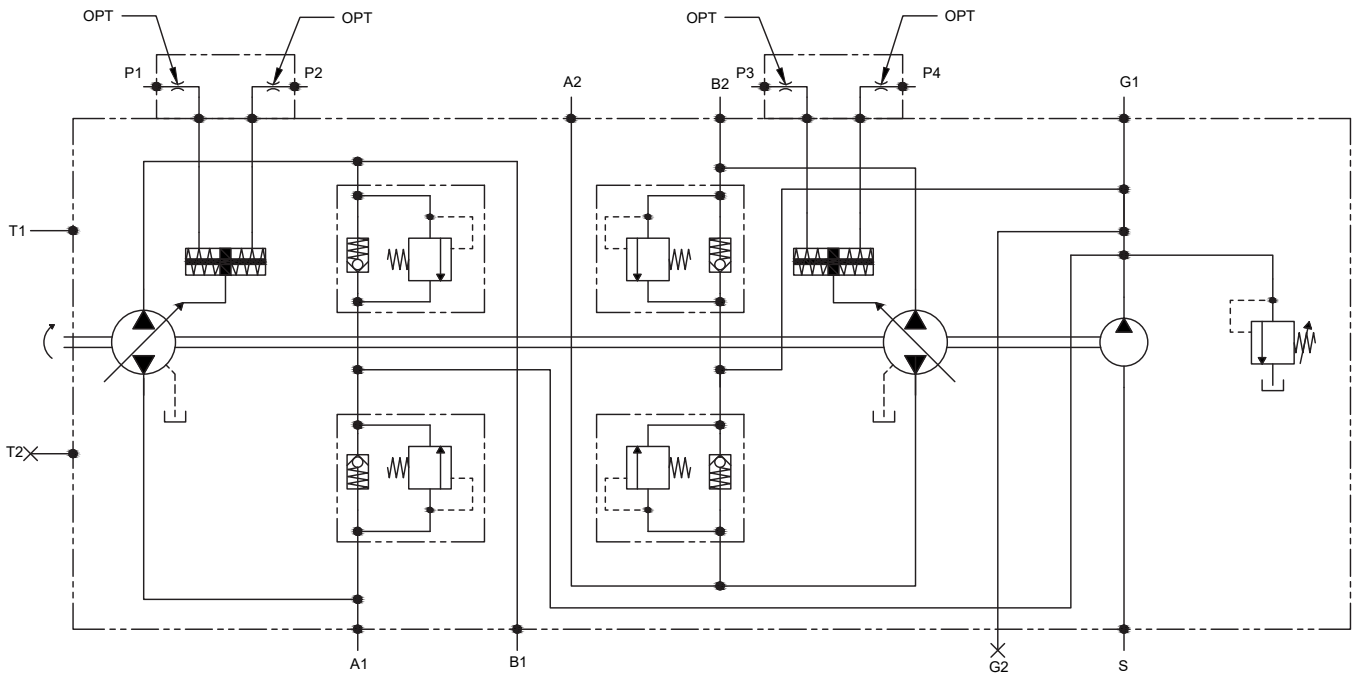

FLOW DIRECTION	PRIMARY PUMP			SECONDARY PUMP		
	Port	OUT	IN	Port	OUT	IN
Clockwise (CR)	P <sub>1</sub>	B <sub>1</sub>	A <sub>1</sub>	P <sub>3</sub>	A <sub>2</sub>	B <sub>2</sub>
	P <sub>2</sub>	A <sub>1</sub>	B <sub>1</sub>	P <sub>4</sub>	B <sub>2</sub>	A <sub>2</sub>
Counter clockwise (CC)	P <sub>1</sub>	A <sub>1</sub>	B <sub>1</sub>	P <sub>3</sub>	B <sub>2</sub>	A <sub>2</sub>
	P <sub>2</sub>	B <sub>1</sub>	A <sub>1</sub>	P <sub>4</sub>	A <sub>2</sub>	B <sub>2</sub>

**SEI 1** (12V DC)  
**SEI 2** (24V DC)

**PROPORTIONAL ELECTRIC SERVO CONTROL**

(AMP junior timer connector)

The pump displacement variation is obtained by an electric signal, which varies approximately:

- from 315 to 630 mA (24V DC voltage)
- from 630 to 1260 mA (12V DC voltage)

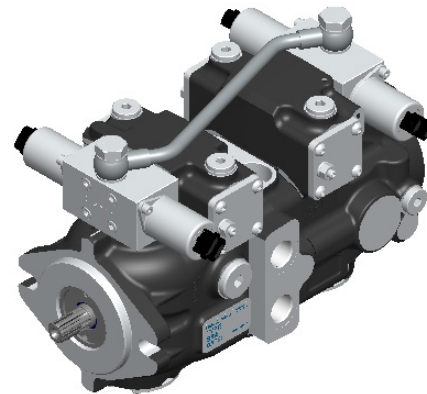
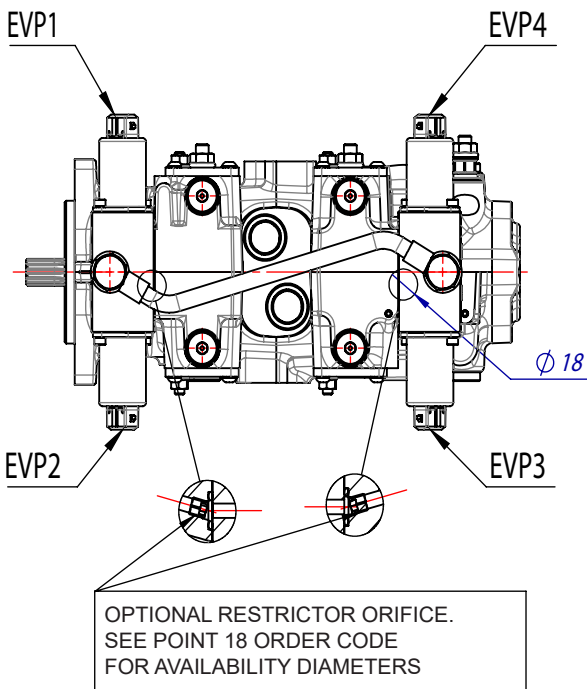
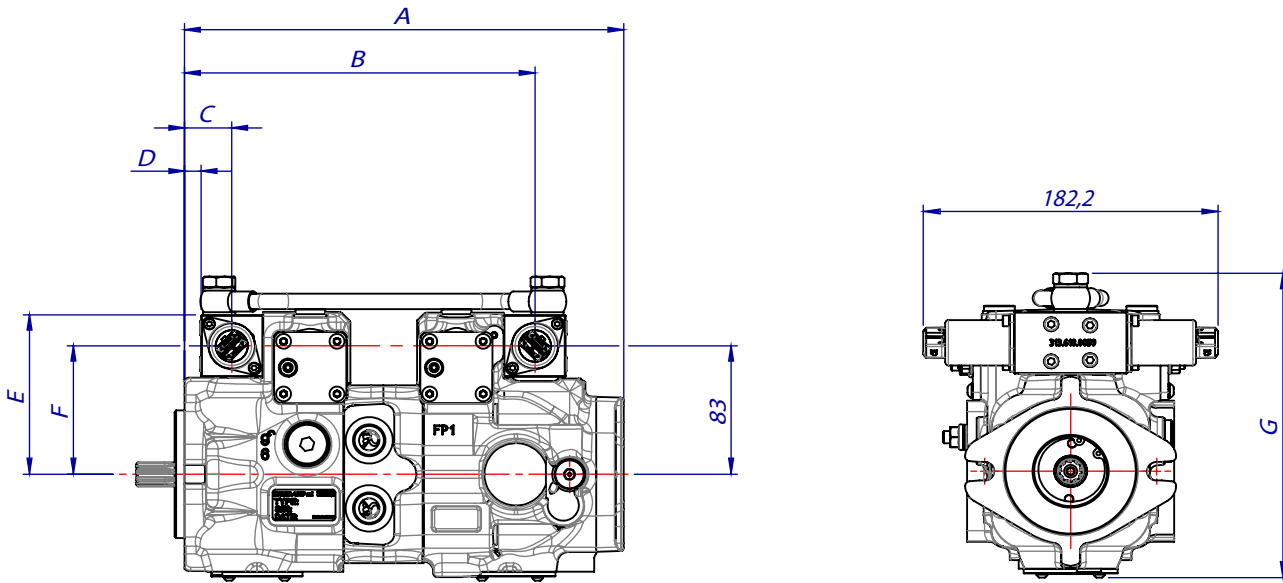

GENERAL DIMENSIONS (mm)		
REFERENCE	F1 - SAE A	F2 - SAE B
A	279,5	280,5
B	223	224
C	30	31
D	10,5	11,5
E	103	103
F	83	83
G	196,5	196,5

(continued)

**SEI 1** (12V DC)

**SEI 2** (24V DC)

**PROPORTIONAL ELECTRIC SERVO CONTROL**

(AMP junior timer connector)

**HYDRAULIC CIRCUIT**

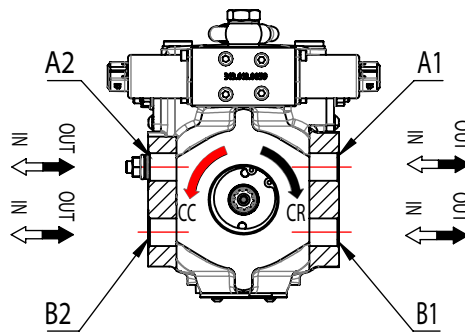
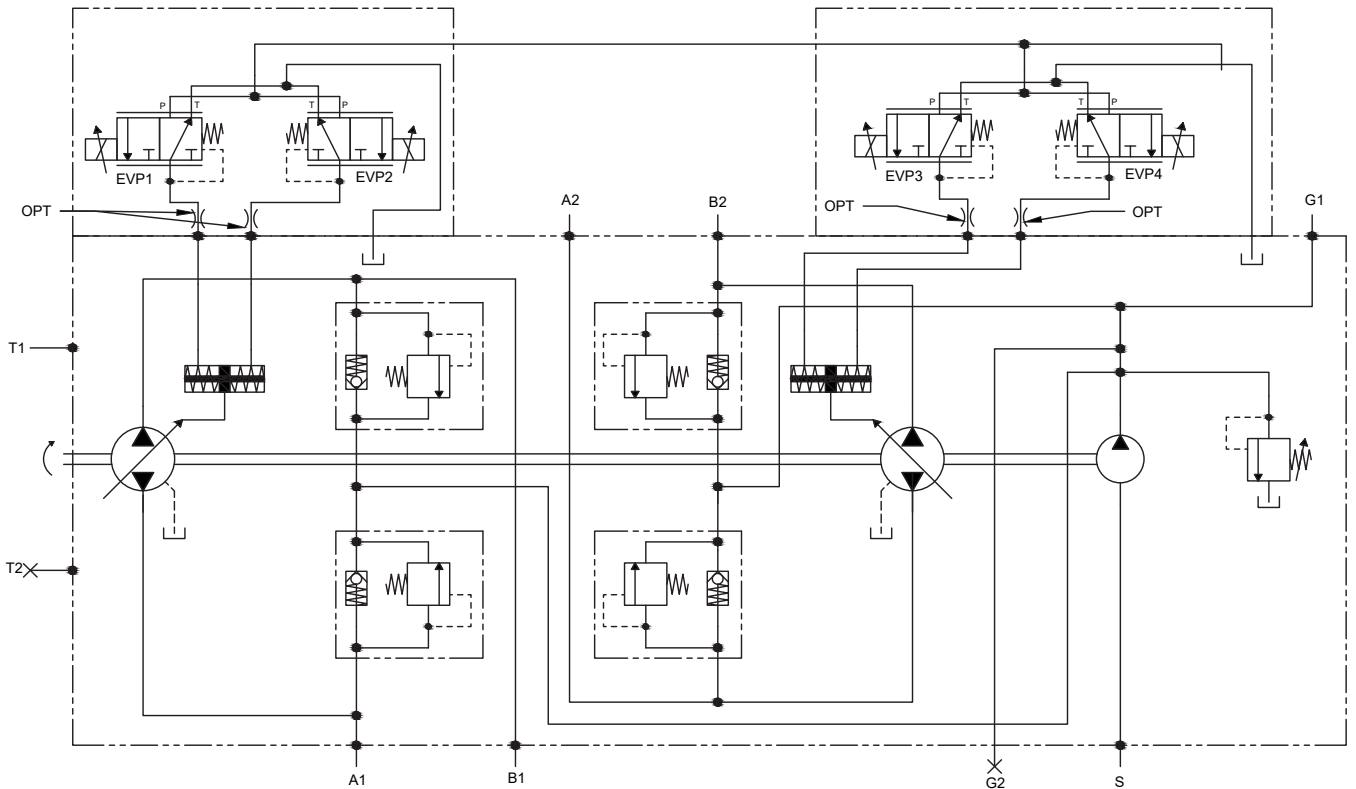

FLOW DIRECTION	PRIMARY PUMP			SECONDARY PUMP		
Rotation	EVP	OUT	IN	EVP	OUT	IN
Clockwise (CR)	EVP1 EVP2	B <sub>1</sub> A <sub>1</sub>	A <sub>1</sub> B <sub>1</sub>	EVP3 EVP4	A <sub>2</sub> B <sub>2</sub>	B <sub>2</sub> A <sub>2</sub>
Counter clockwise (CC)	EVP1 EVP2	A <sub>1</sub> B <sub>1</sub>	B <sub>1</sub> A <sub>1</sub>	EVP3 EVP4	B <sub>2</sub> A <sub>2</sub>	A <sub>2</sub> B <sub>2</sub>

(continued)

**SEI 1** (12V DC)

**SEI 2** (24V DC)

**PROPORTIONAL ELECTRIC SERVO CONTROL**

(AMP junior timer connector)

**CURRENT-DISPLACEMENT GRAPHIC**

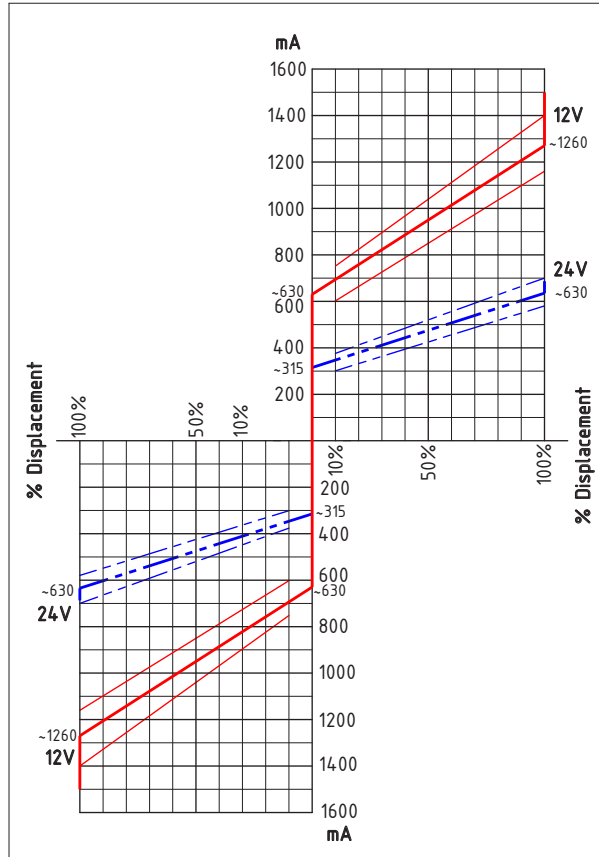

ELECTRICAL FEATURES		
Voltage	12 V DC	24 V DC
Electric current	1500 mA	750 mA
Load resistance	4,72 Ω ± 5%	20,8 Ω ± 5%
Type of control	Current control	
	PWM 100 Hz (suggested)	
Type of connection	AMP Junior Timer	
Protection class	Until IP6K6 / IPX9K	

HYDRAULIC FEATURES	
Max. pressure (P, T)	pP= 5 MPa, pT= 3 MPa
Hysteresis (w/PWM)	<0,07 MPa (pA=2,0)
	<0,1 MPa (pA=2,5)
	<0,15 MPa (pA=3,5)
Filtration ratio	125 μm
Oil contamination level	Min. filtration ratio: 20/18/15
	According ISO 4406
	Hydraulic oil DIN 51524
Min./max. oil temperature	From -20 to +90°C



**SEI 1D** (12V DC)  
**SEI 2D** (24V DC)

**ELECTRO SERVO PROPORTIONAL CONTROL**  
(DEUTSCH connector)

The pump displacement variation is obtained by an electric signal, which varies approximately:

- from 315 to 630 mA (24V DC voltage)
- from 630 to 1260 mA (12V DC voltage)

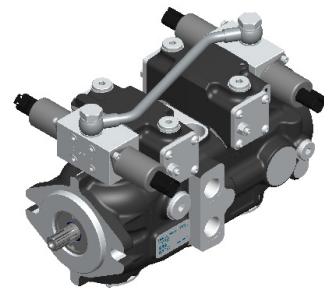
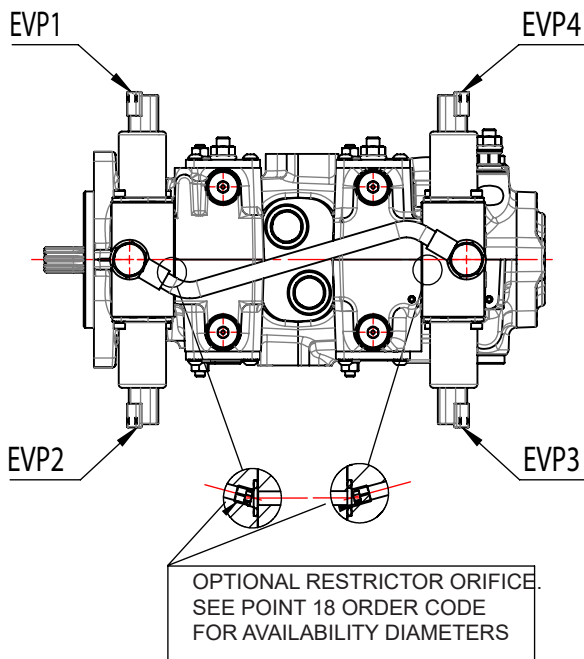
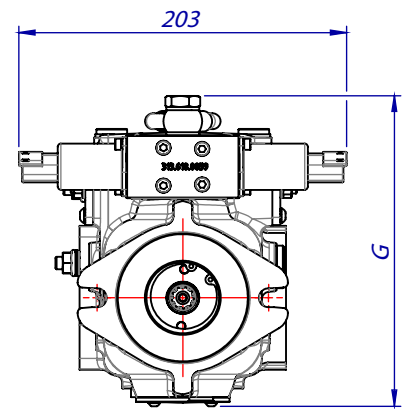
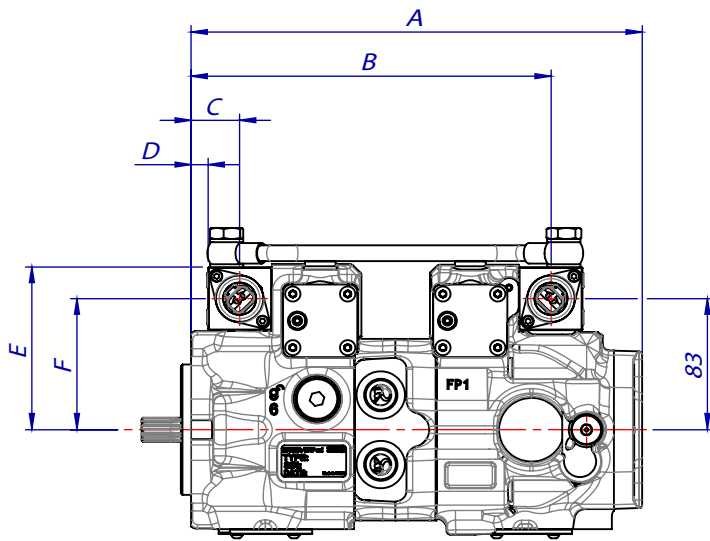

GENERAL DIMENSIONS (mm)		
REFERENCE	F1 - SAE A	F2 - SAE B
A	279,5	280,5
B	223	224
C	30	31
D	10,5	11,5
E	103	103
F	83	83
G	196,5	196,5

(continued)

**SEI 1D** (12V DC)

**SEI 2D** (24V DC)

**ELECTRO SERVO PROPORTIONAL CONTROL**

(DEUTSCH connector)

**SCHEMA IDRAULICO**

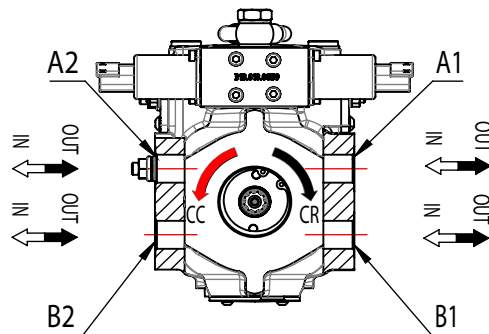
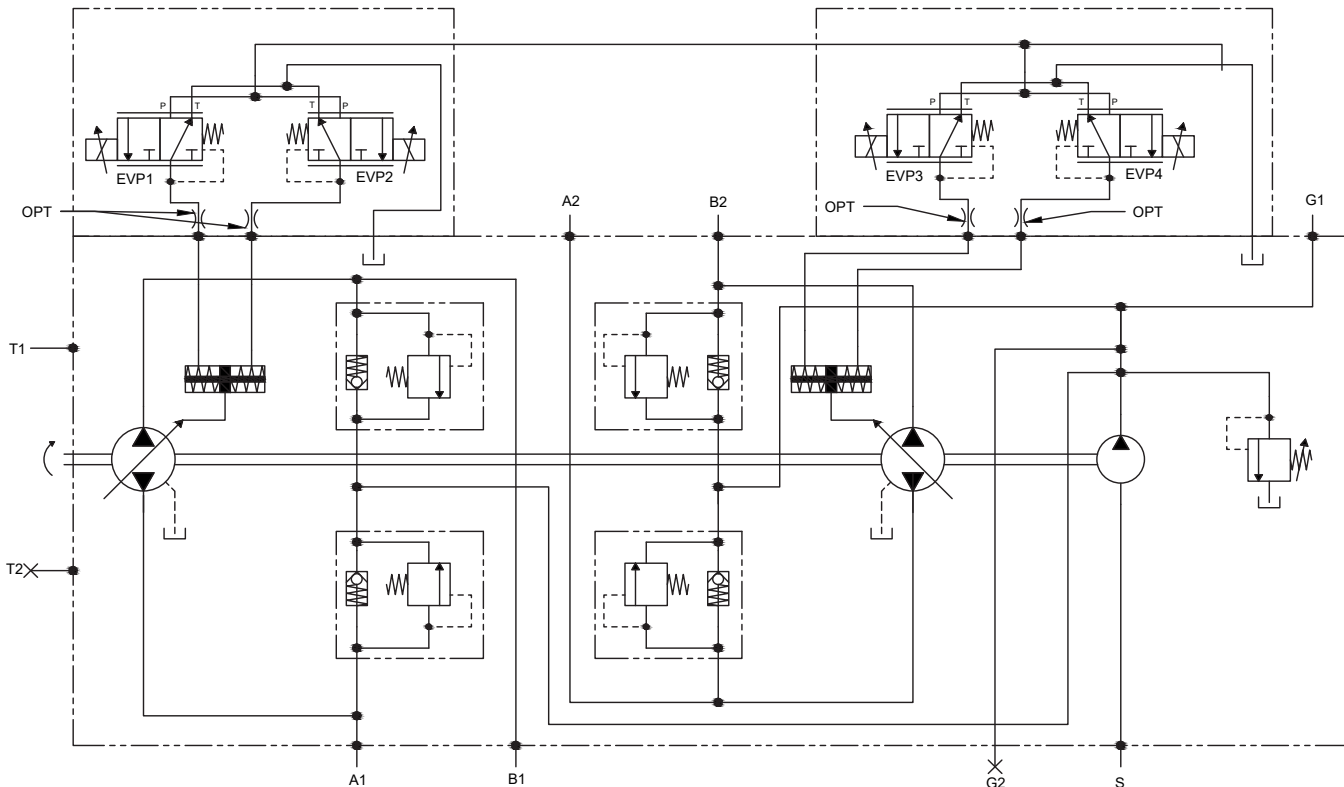

FLOW DIRECTION	PRIMARY PUMP			SECONDARY PUMP		
Rotation	EVP	OUT	IN	EVP	OUT	IN
Clockwise (CR)	EVP1 EVP2	B <sub>1</sub> A <sub>1</sub>	A <sub>1</sub> B <sub>1</sub>	EVP3 EVP4	A <sub>2</sub> B <sub>2</sub>	B <sub>2</sub> A <sub>2</sub>
Counter clockwise (CC)	EVP1 EVP2	A <sub>1</sub> B <sub>1</sub>	B <sub>1</sub> A <sub>1</sub>	EVP3 EVP4	B <sub>2</sub> A <sub>2</sub>	A <sub>2</sub> B <sub>2</sub>

**CONTROL DEVICE POSITION**

(Primary and Secondary Pump)

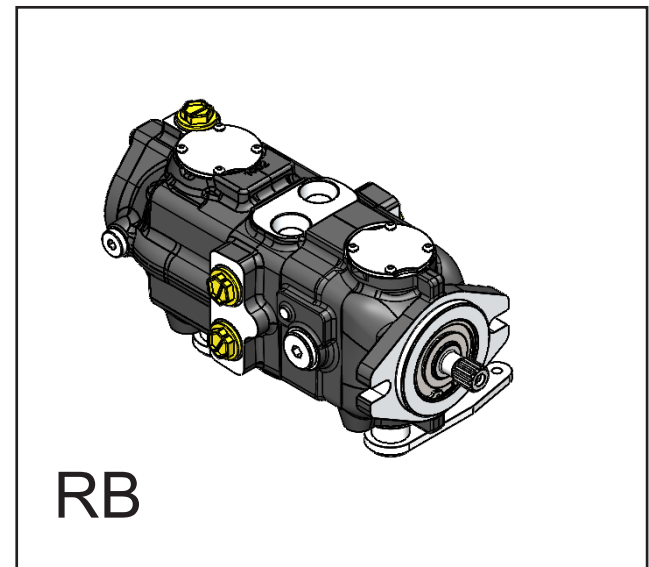
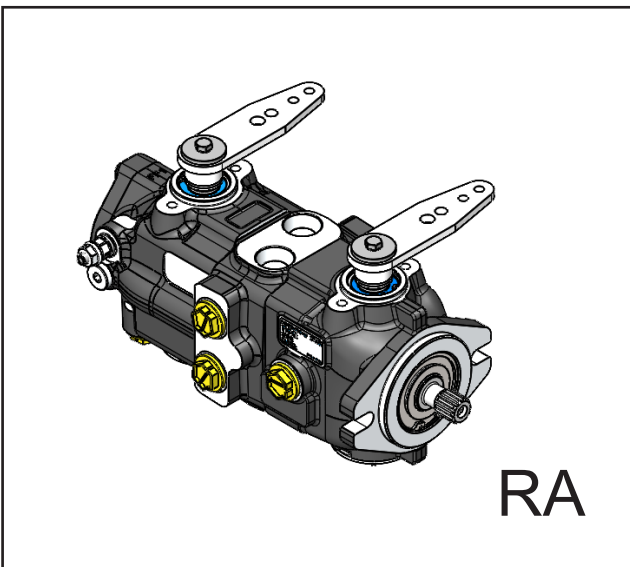
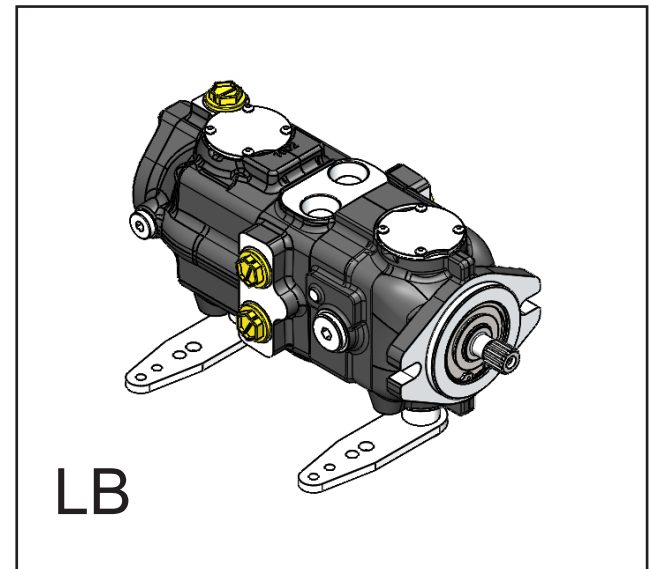
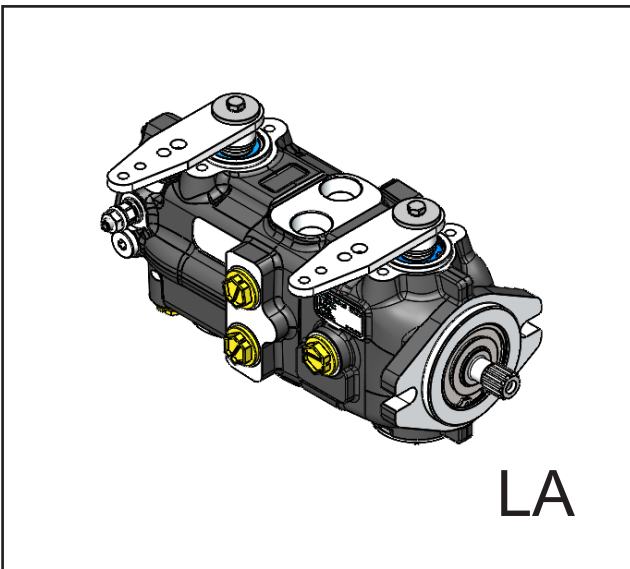
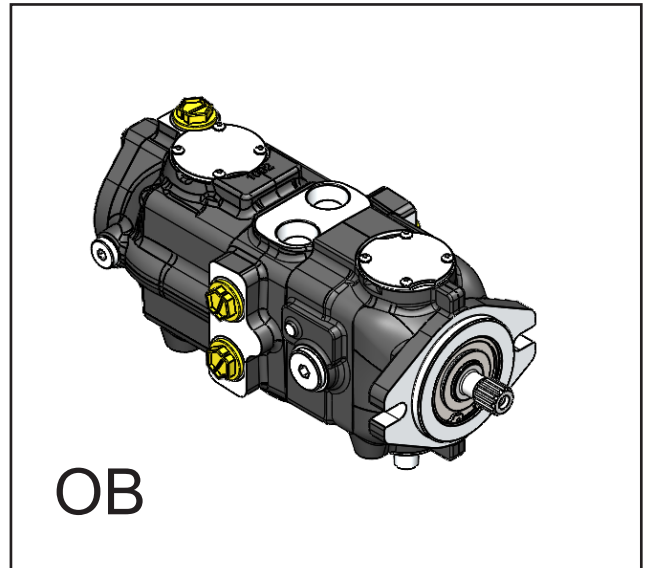
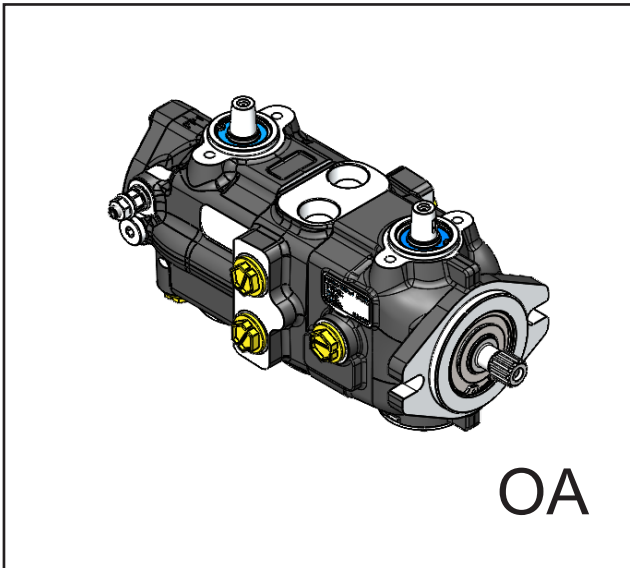

**CONTROL DEVICE POSITION**

(Primary and Secondary Pump)

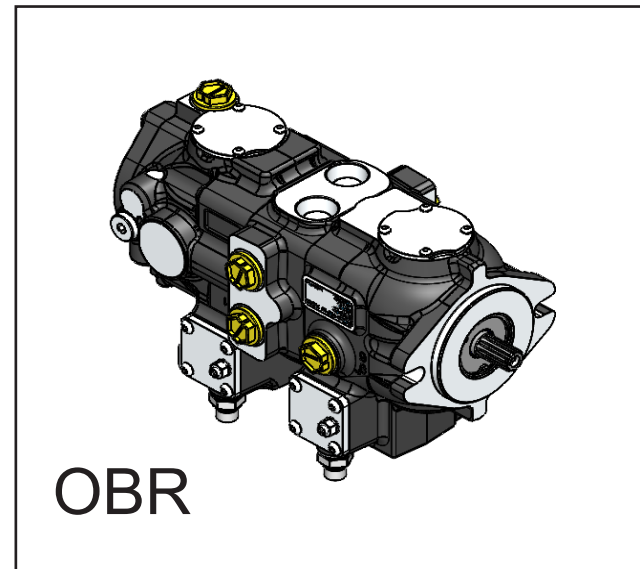
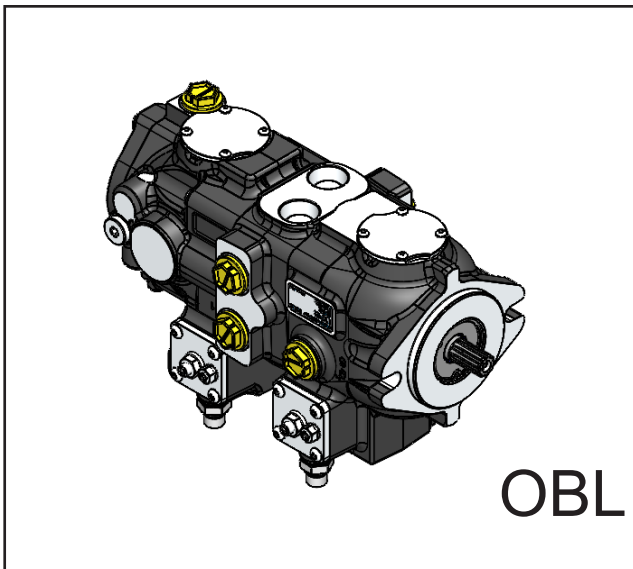
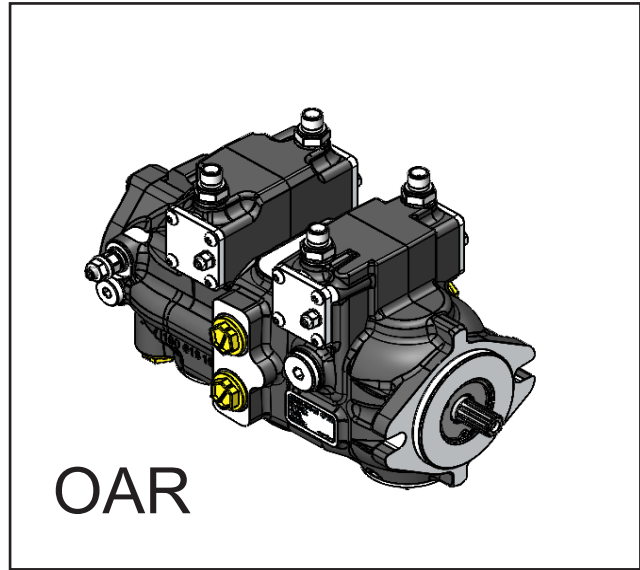
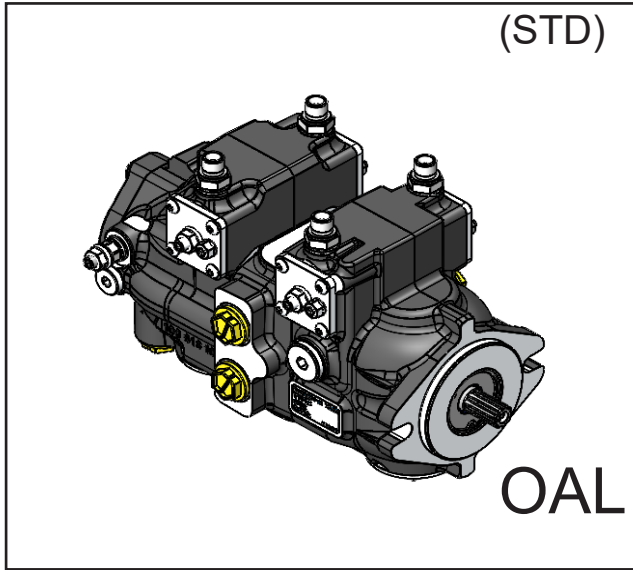

**REAR PUMP MOUNTING FLANGES**

**C  
CLOSED COVER WITHOUT REAR FITTING**

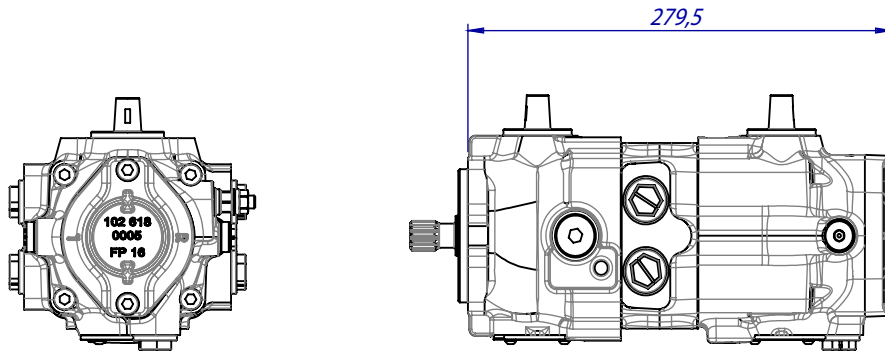

**B1  
GERMAN STANDARD**

Four possible mounting positions (every 90°)  
Max. torque = 70 Nm

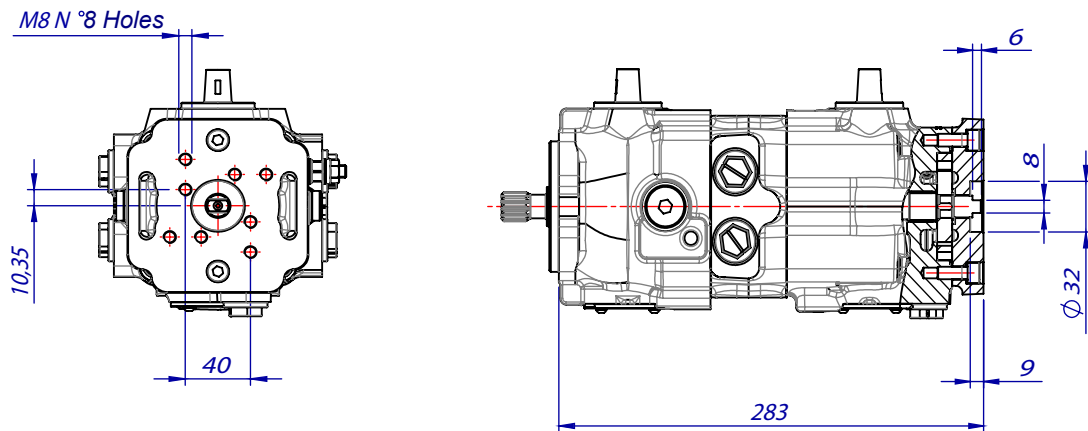

**B2  
GERMAN STANDARD**

Four possible mounting positions (every 90°)  
Max. torque = 70 Nm

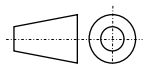
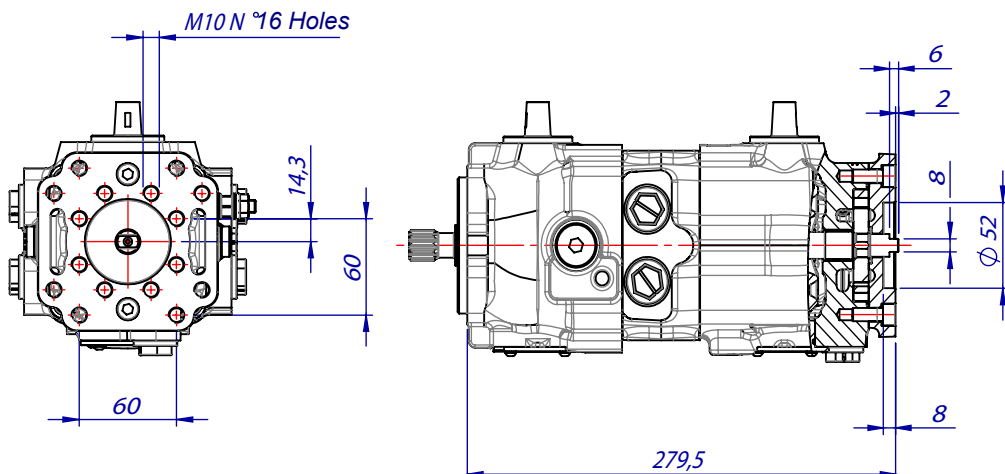

**GEAR PUMPS CONNECTION**

**F**

**OPTIONAL  
GROUP 1**

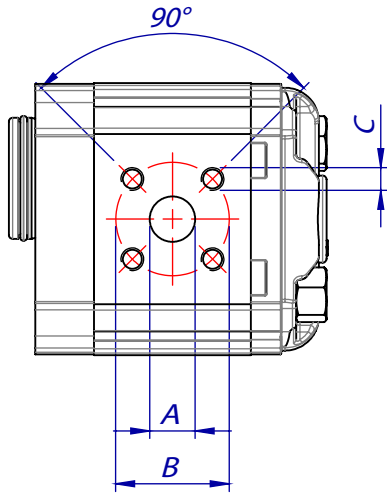

PUMP CONNECTION SIZE					
SUCTION IN			OUTLET OUT		
A	B	C	A	B	C
12 mm	30 mm	M6	12 mm	30 mm	M6

**G**

**STANDARD  
GROUP 1**

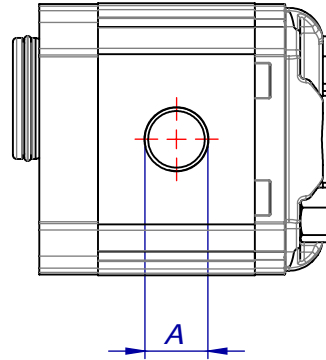

PUMP CONNECTION SIZE	
SUCTION IN	OUTLET OUT
A	A
3/8" BSPP	3/8" BSPP

**STANDARD  
GROUP 2**

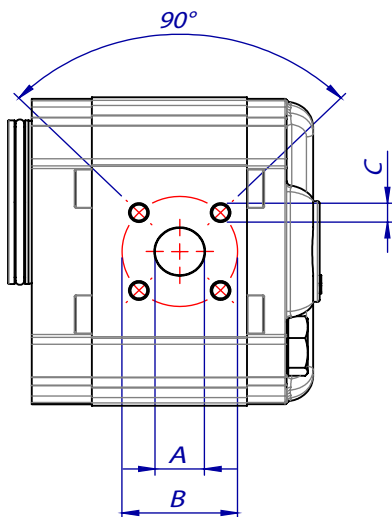

PUMP CONNECTION SIZE					
SUCTION IN			OUTLET OUT		
A	B	C	A	B	C
20 mm	40 mm	M6	15 mm	35 mm	M6

**OPTIONAL  
GROUP 2**

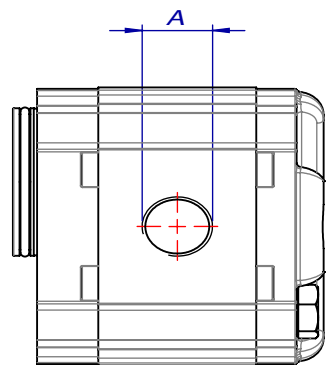

PUMP CONNECTION SIZE		
DISPLACEMENT	SUCTION IN	OUTLET OUT
cm <sup>3</sup> /n	A	A
4	G 1/2"	G 1/2"
6		
8		
11	G 3/4"	
14		
16		
19		
22		
26	G 1/2"	
31		

# OPTIONAL FB

ADAPTOR FLANGE FROM SAE A - SAE B

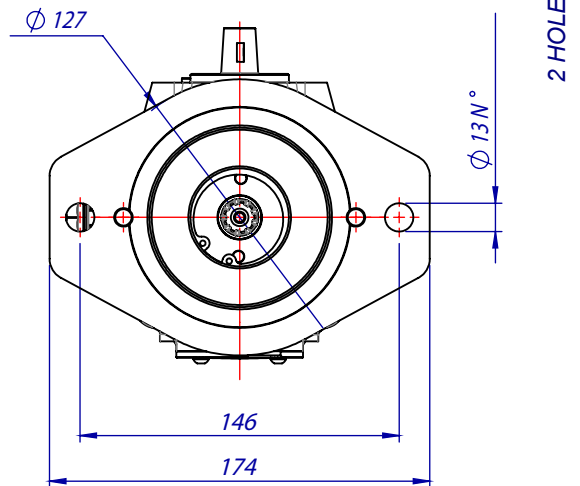
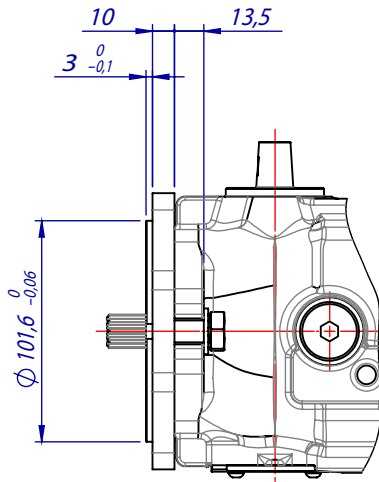

# OPTIONAL ST

COUPLING Z = 9 / Z = 13

(SAE-A / SAE-B CONVERSION OF SHAFT)

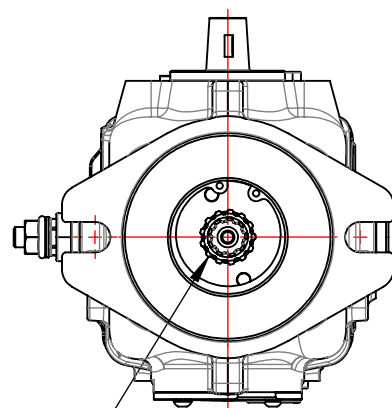
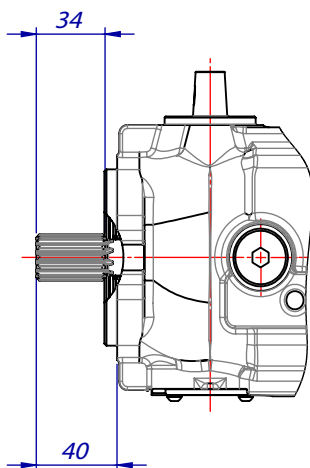

Z13 16/32 D.P.  
SPLINED

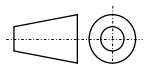



# OPTIONAL VS-SB FLUSHING VALVE WITH SCREW BY-PASS

The TPV 1300 BTB pumps are available with flushing valve with screw by-pass.

The valve consists of a spring centered shuttle spool connecting automatically the low pressure line (boost) with the reservoir removing heat from the system. The quantity of the flushing oil is a function of the low system pressure (boost) and the size of the orifice on the valve (different orifices are available referred to the system pressure). The spool shifts at a differential pressure of about 0,8 MPa (116 PSI).

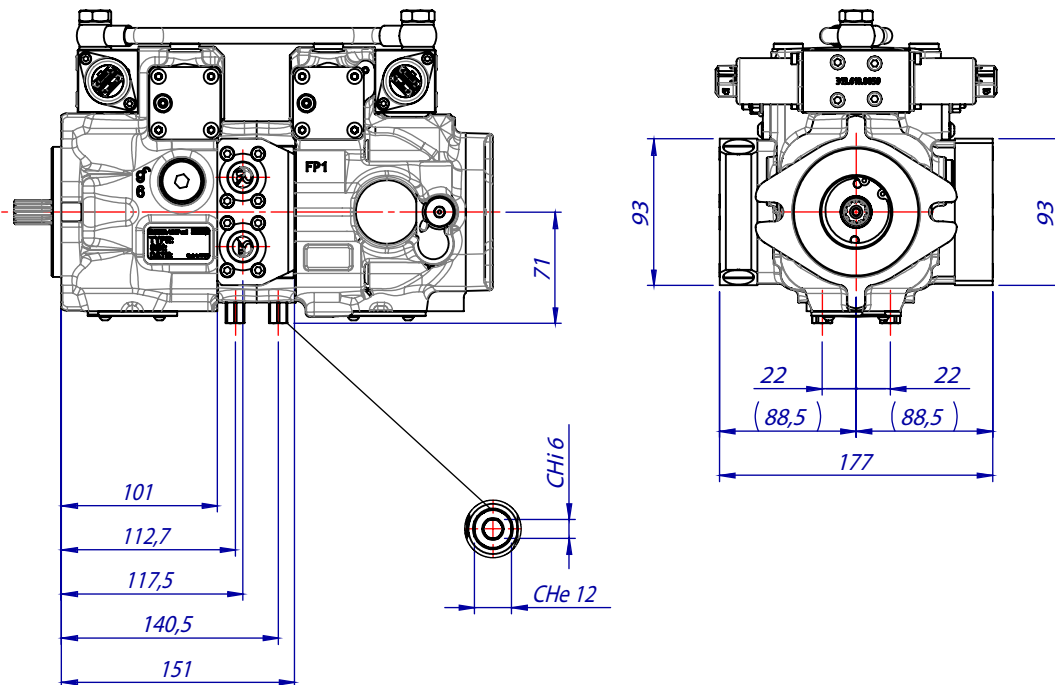
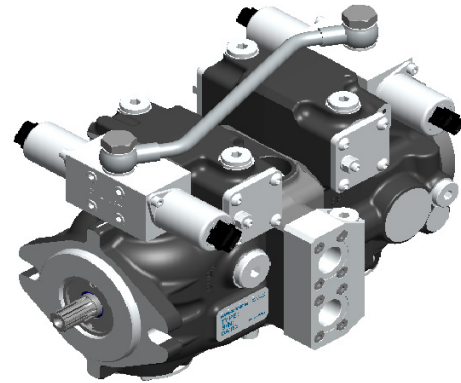

**HYDRAULIC CIRCUIT**

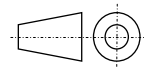
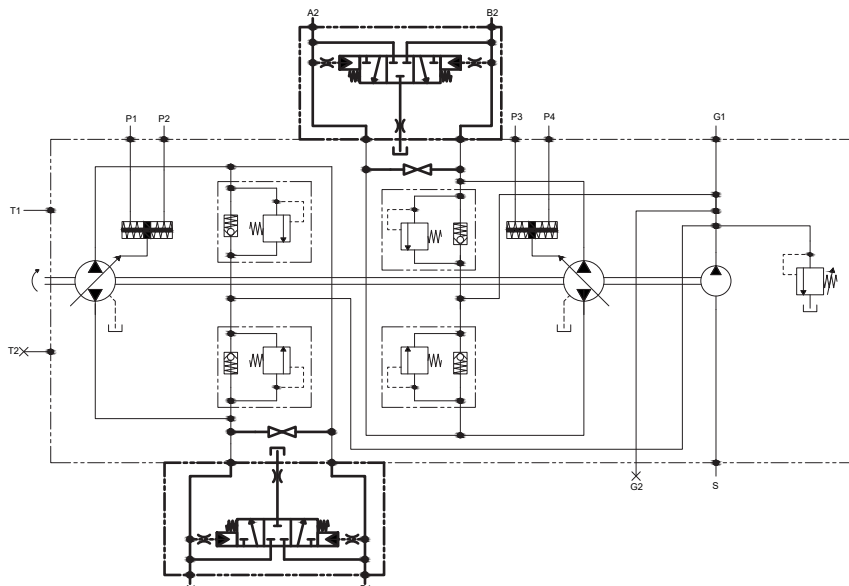



# OPTIONAL VS-SB1

## FLUSHING VALVE WITH SCREW BY-PASS (180° rotated position)

The TPV 1300 BTB pumps are available with flushing valve with screw by-pass in 180° rotated position. The valve consists of a spring centered shuttle spool connecting automatically the low pressure line (boost) with the reservoir removing heat from the system. The quantity of the flushing oil is a function of the low system pressure (boost) and the size of the orifice on the valve (different orifices are available referred to the system pressure). The spool shifts at a differential pressure of about 0,8 MPa (116 PSI).

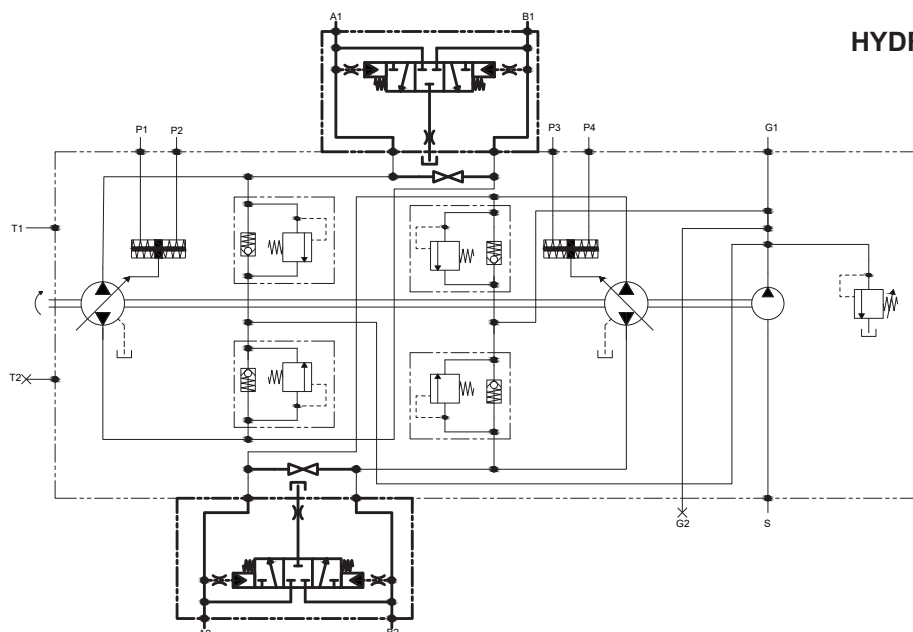
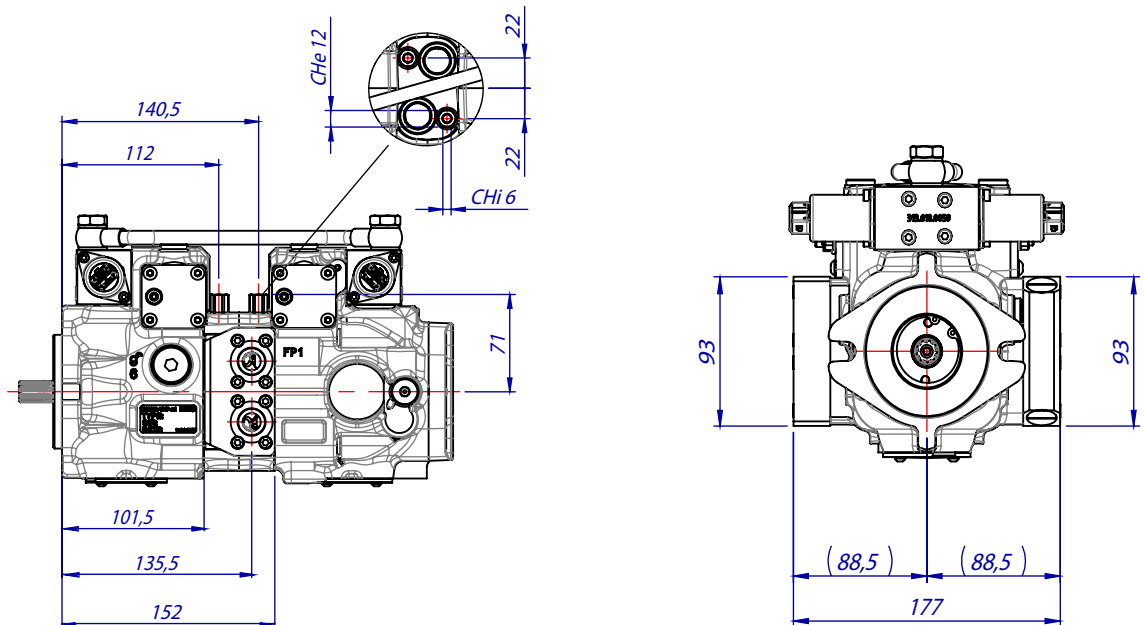
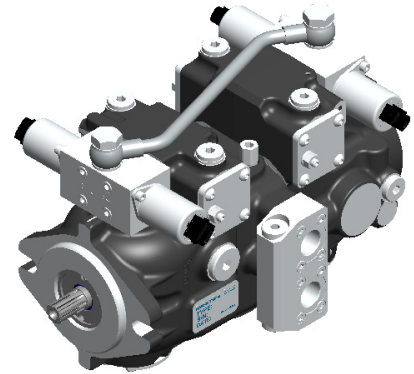

**HYDRAULIC CIRCUIT**

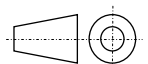

# OPTIONAL SB

## SCREW BY-PASS

To by pass the oil flow from one direction to the other, with the pump not running or in emergency condition a by pass screw can be actuated to connect the 2 lines of the hydraulic system. The orifice is completely open after 4 counter-clockwise rotations of the screw.

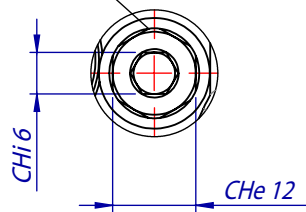
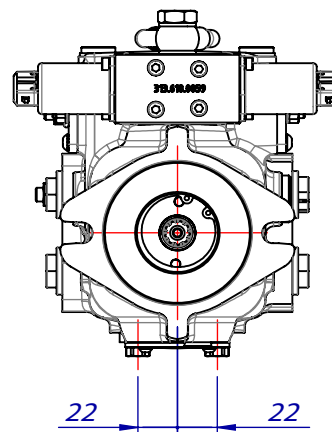
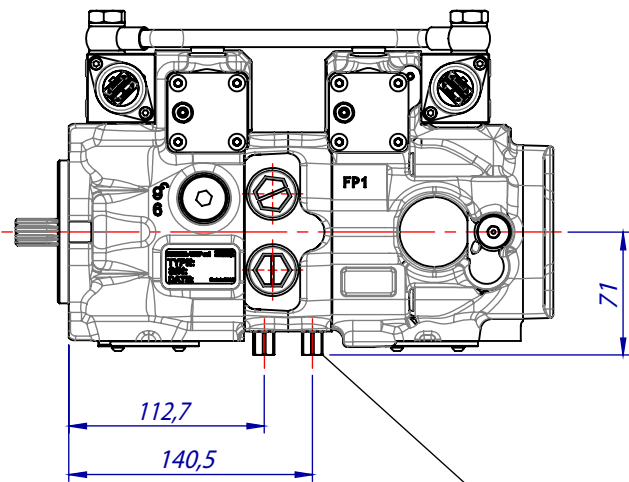
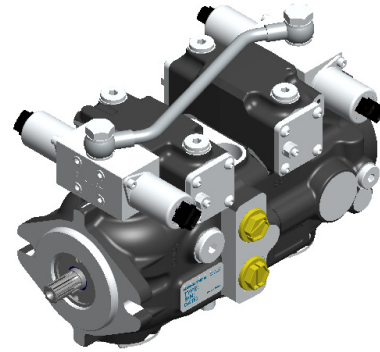

**HYDRAULIC CIRCUIT**

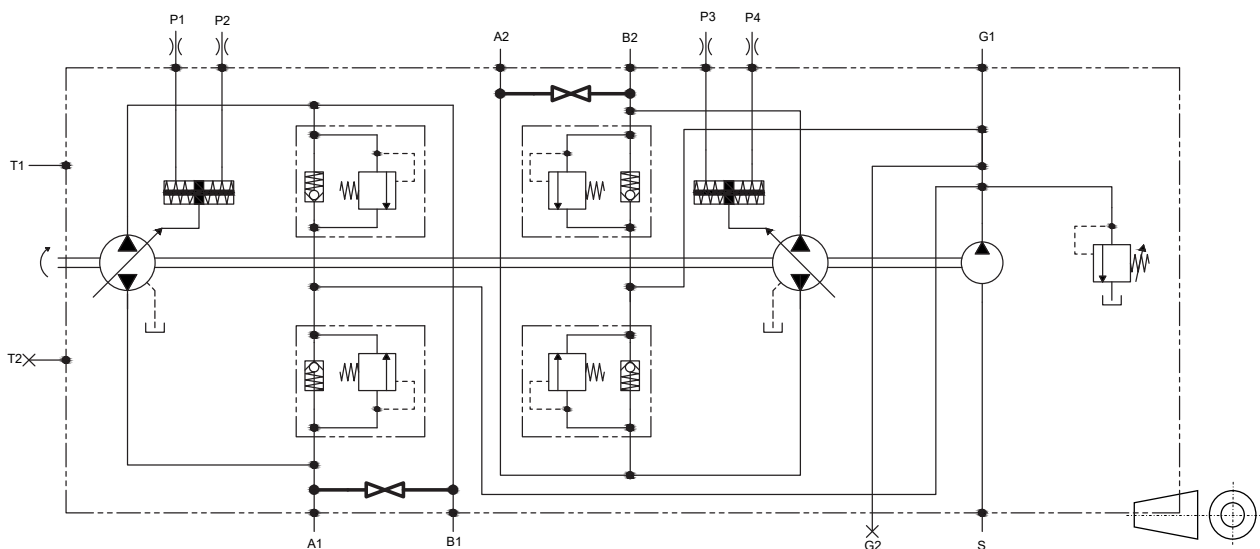

# OPTIONAL SB1

## SCREW BY-PASS (180° rotated position)

To by pass the oil flow from one direction to the other, with the pump not running or in emergency condition a by pass screw can be actuated to connect the 2 lines of the hydraulic system. The orifice is completely open after 4 counter-clockwise rotations of the screw.

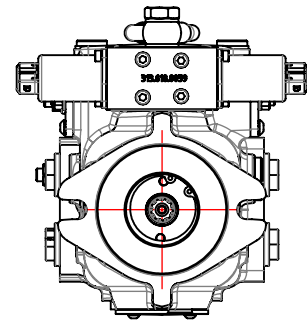
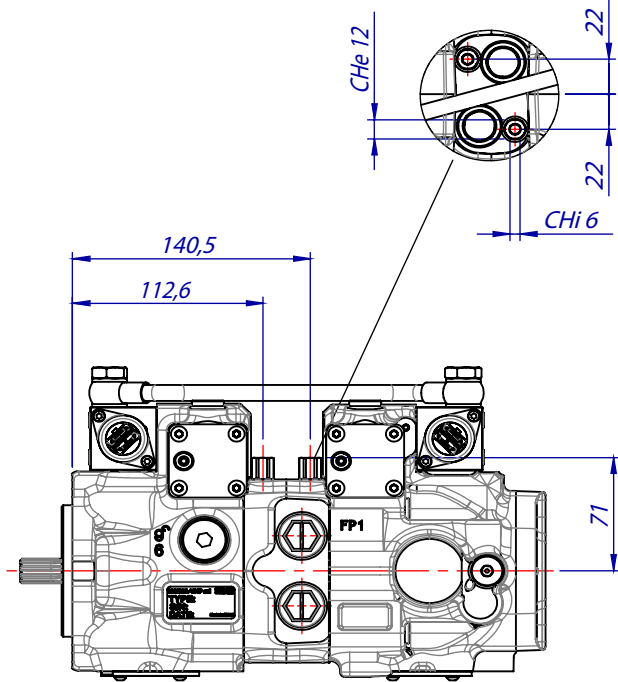
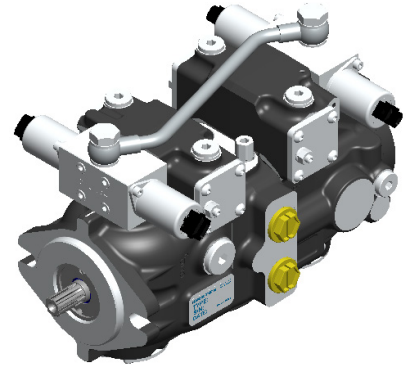

### HYDRAULIC CIRCUIT

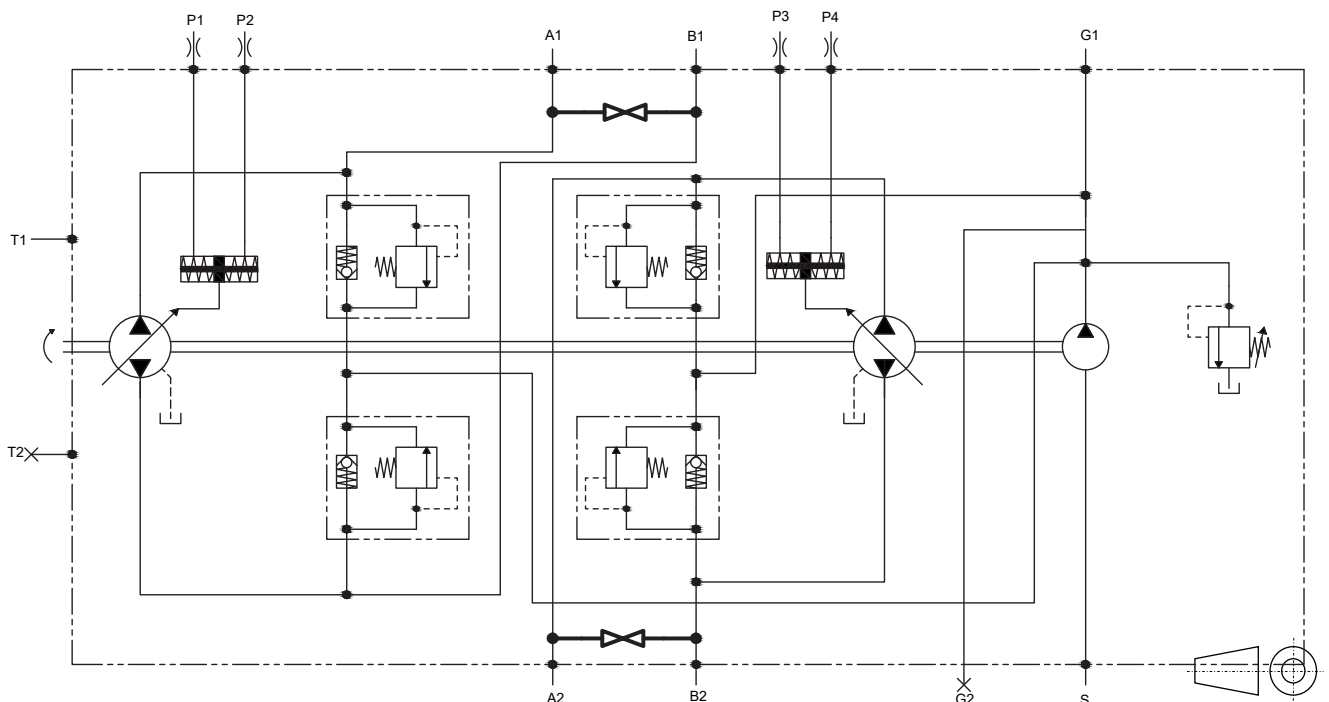



# OPTIONAL MOB

## MAN ON BOARD

A normally open solenoid valve cuts the oil flow when not activated.

The valve allows oil flow to feed the hydraulic system only if activated (the operator is seated).

The solenoid valve is available for 12V or 24V DC voltage.

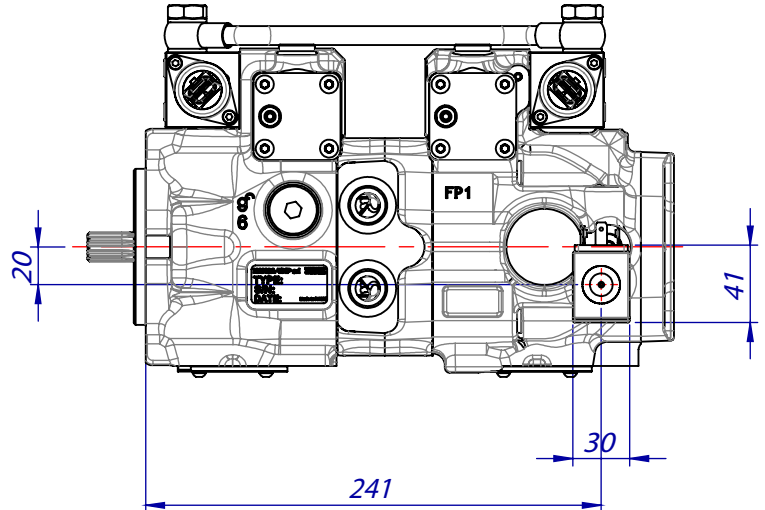
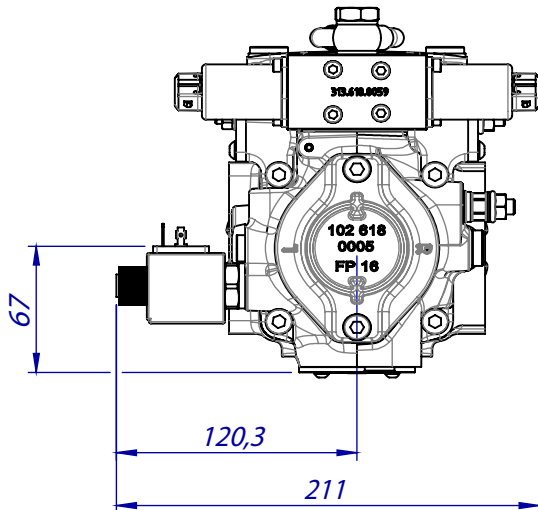
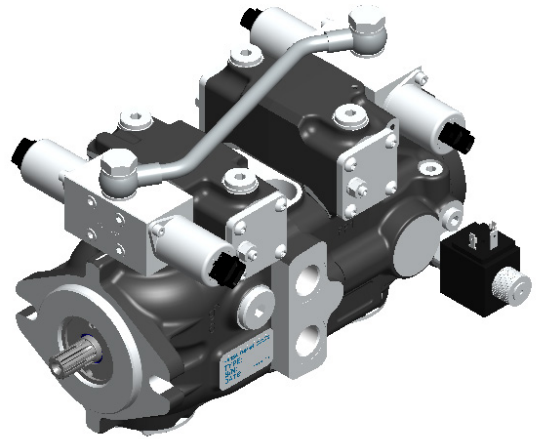

### HYDRAULIC SCHEME

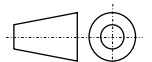
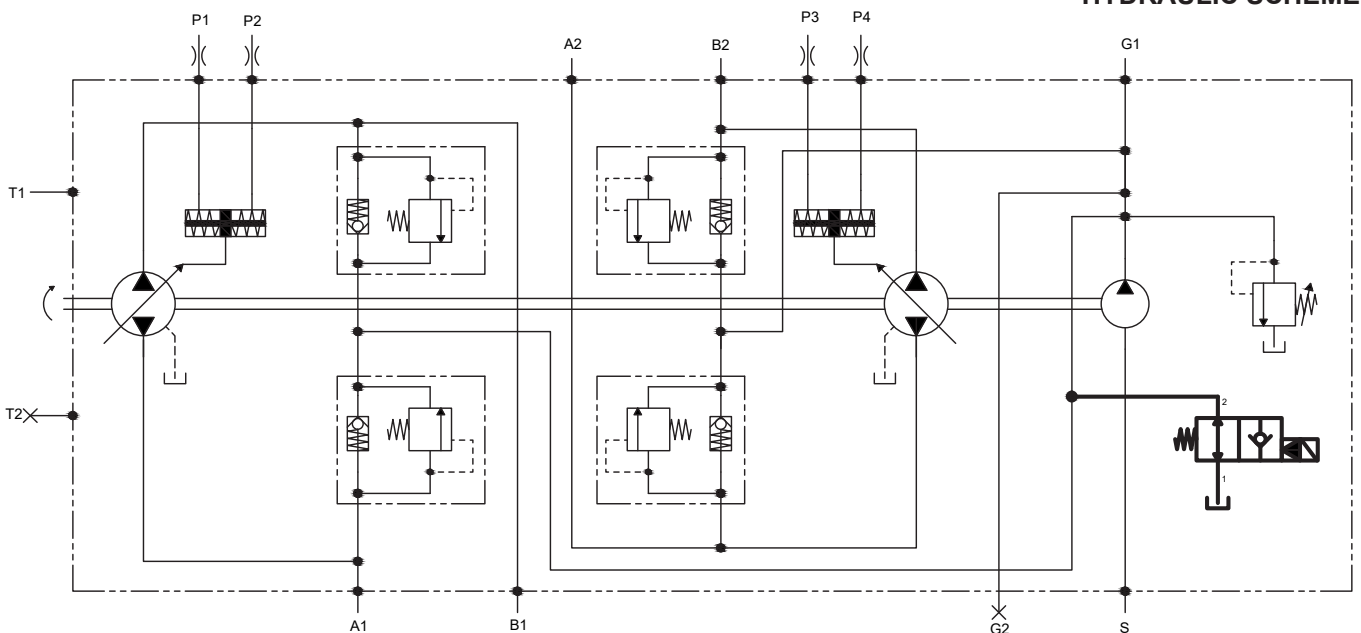

(continued)

# OPTIONAL MOB

**MAN ON BOARD**

## TECHNICAL FEATURES

VALVE MOB - Hydraulic characteristics	
Max. operating pressure	30 MPa
Max. flow	40 l/min.
Internal leakage	max. 5 drops/min. at 30 MPa
Response time	energized 20 ms
De-energized	30 ms
Temperature range	from -20°C to 90°C

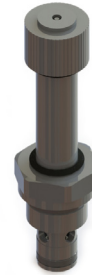

VALVE MOB - Electrical characteristics	
Power	18 W
Various voltage options available	(AC/DC)
Wire insulation	Class H
Duty factor	ED 100%
Supply power tolerance	+ 10%, - 15% (DC)
Ambient temperature	from -30°C to 60°C
Several connection options available	

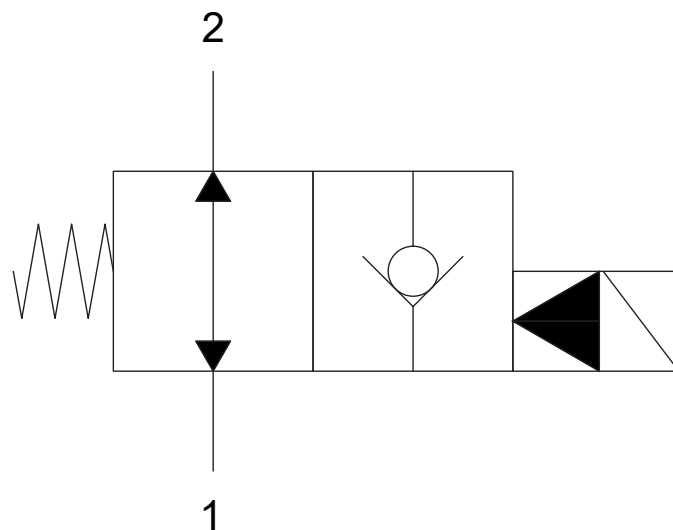

**TROUBLESHOOTING**

TROUBLES	CAUSE	REMEDY
High noise level	Too high rotation speed of the pump.	Reduce pump rotation speed.
	Wrong rotation direction.	Check the rotation direction of the pump.
	Obstruction in suction line - air in the suction line - wrong oil viscosity - diameter of suction line too small.	Check oil type and viscosity. Check internal diameter of suction line. Remove restrictions. Check oil level of reservoir. Eliminate air intake.
	Not correct connection of the pump. Not correct diameter of pipes / hoses.	Check the pump connections and the pipe / hose diameters according to notes.
	Vibrations of relief valves .	Check the inlet suction line - Check and replace relief valves.
	Internal parts worn out.	Check and replace.
	Wrong pump connection to the prime mover.	Check connections and rotation of direction.
	Too low rotation speed of the pump.	Increase the pump rotation speed.
Low flow rate	Obstructions in the suction line - wrong viscosity.	Check oil type and viscosity. Check internal diameter of suction line. Remove restrictions. Check oil level of reservoir. Eliminate air intake.
	Low remote control pressure.	Check and adjust.
	High internal leakage.	Check the case drain flow.
	Low rotation speed of the pump.	Increase speed of the pump.
Instable or low pressure	Obstruction of suction line - air in the suction line - wrong oil viscosity - diameter of suction line too small.	Check oil type and viscosity. Check internal diameter of suction line. Remove restrictions. Check oil level of reservoir. Eliminate air intake.
	Vibration of relief valves.	Check the inlet suction line. Check and replace relief valves.
	Internal parts worn out.	Check and replace.
Over heating	High oil temperature at suction inlet.	Check the cooling system.
	Internal parts worn out.	Check - replace.
	Wrong setting of pressure relief valves.	Check - adjust the setting of relief valves.

**ACCESSORIES**

**Hydraulic Gear Pump German Standard B1**

**Hydraulic Gear Pump German Standard B2**

For more detailed information ask  
for catalogue HT 15 F 206 0518 IE

**Hydraulic Remote Servo Controls**



For more detailed information ask  
for catalogue HT 73 B 105 0919 E

**Electric and Electronic Remote Servo Controls**



For more detailed information ask  
for catalogue HT 73 B 203 0516 E

**Belt Drive Support BDS SAE-A / SAE-B**

For more detailed information ask

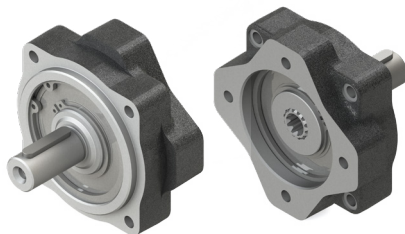

**SAE-A**

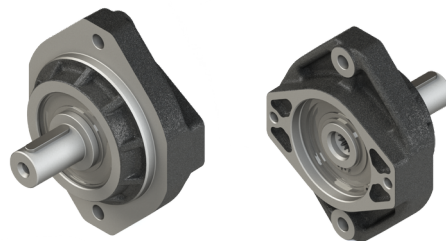

**SAE-B**

**Bell Housings and Couplings for Pump Assembly on Internal Combustion Engines**

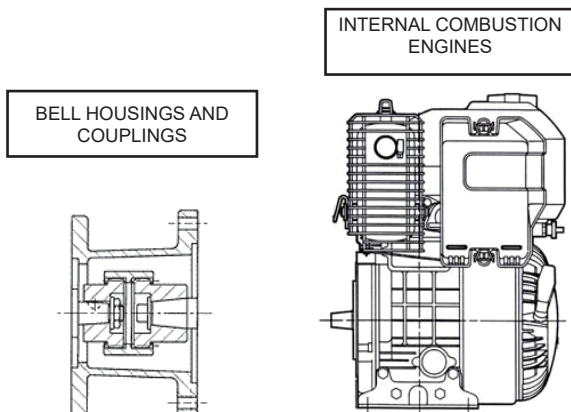

For more detailed information ask  
our technical department.



**TRIPLE PUMP - CONFIGURATION EXAMPLE**

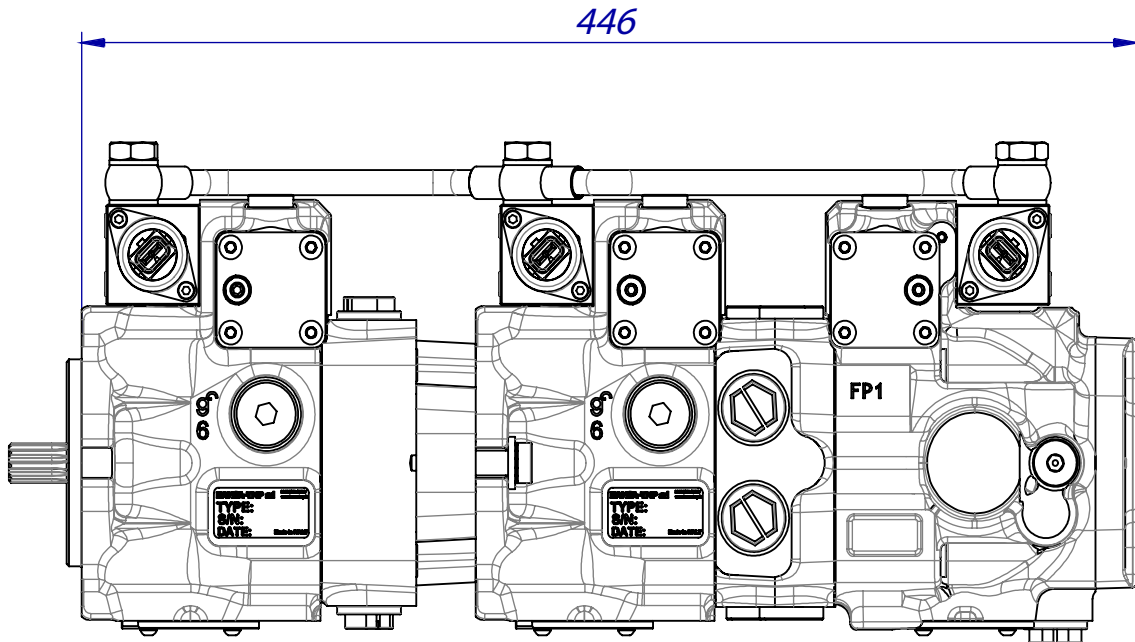

**HYDRAULIC CIRCUIT**

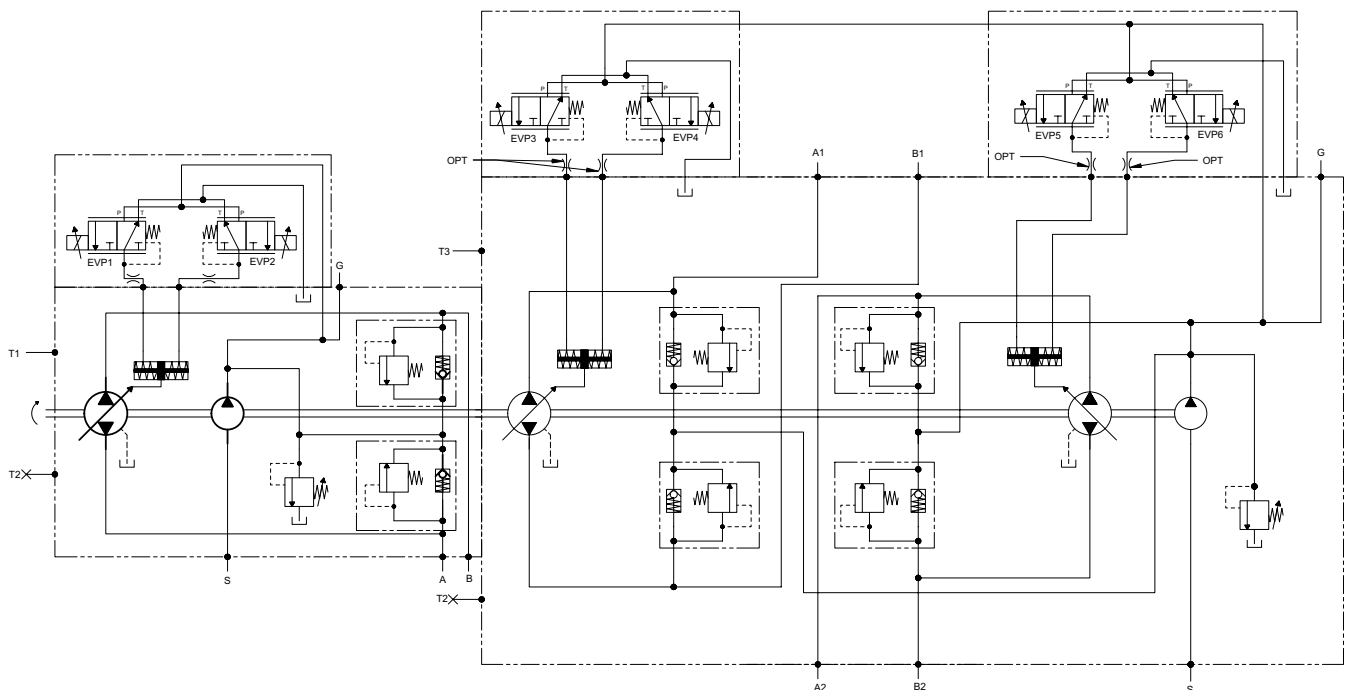

## PUMPS



Closed Loop Axial Piston Pumps (Variable Displacement) - 6-110 cc

Model	Displacement cm <sup>3</sup> /n.	Rated Pressure MPa	Peak Pressure MPa	Maximum speed n/min.	Weight kg (single pump)
TPV 1100 TPV 1300	6, 8, 9, 11, 12, 13	30	35	3.600	8,8
	15, 17		30		
	18		30		
	19, 21	22	28	3.200	
TPV-TPVTC 1500	17, 18, 19, 21	35	40	3.600	14
TPV 3200	21, 28	25	35		22
TPV-TPVT 3600	26, 28, 30, 31, 32, 34, 36, 38, 43	40	45		28
TPV 4300	32, 38, 45, 50	28	35		23
TPV 5000	46, 50, 64	30	40		29
TPV 9000	55	40	45	4.000	55
	72			4.100	68
	90			4.000	
	110			3.800	



Open Loop Axial Piston Pumps (Fixed Displacement) - 32-50 cc

Model	Displacement cm <sup>3</sup> /n.	Rated Pressure MPa	Peak Pressure MPa	Maximum speed n/min.	Weight kg (single pump)
TPF 60	35, 40, 46	35	42	2.800	20,5
	50		41	2.500	



Bent Axis Pumps - 12-130 cc

Model	Displacement cm <sup>3</sup> /n.	Rated Pressure MPa	Peak Pressure MPa	Maximum speed n/min.	Weight kg
TPB - TAP 70	12.6	35	40	3.300	7,5
	17.0			3.200	
	25.4			2.550	8,5
	34.2			2.250	
	41.2, 47.1			2.200	15,5
	56.0			2.100	
	63.6			2.050	
	83.6, 90.7, 108.0			1.700	27,0
	130.0			1.600	29,5

The table values can change in function of the configuration.

This page has deliberately left blank.

As HANSA-TMP has a very extensive range of products and some products have a variety of applications, the information supplied may often only apply to specific situations.

If the catalogue does not supply all the information required, please contact HANSA-TMP.

In order to provide a comprehensive reply to queries we may require specific data regarding the proposed application.

Whilst every reasonable endeavour has been made to ensure accuracy, this publication cannot be considered to represent part of any contract, whether expressed or implied.

The data in this catalogue refer to the standard product. The policy of HANSA-TMP consists of a continuous improvement of its products. It reserves the right to change the specifications of the different products whenever necessary and without giving prior information.



**HANSA-TMP S.r.l.**  
Via M. L. King, 6 – 41122 Modena (ITALY)  
Tel.: +39 059 415 711  
Fax: +39 059 415 730  
hansatmp@hansatmp.it  
www.hansatmp.com

Certified Company  
ISO 9001:2015 – ISO 14001:2015



Share Capital: € 300.000,00  
VAT Number: IT01167360369  
REA Number: MO-225785